

**OPERATOR, UNIT, AND DIRECT SUPPORT MAINTENANCE MANUAL
INCLUDING REPAIR PARTS AND SPECIAL TOOLS LIST**

**for
TELESCOPE, STRAIGHT: M145
(1240-01-411-6350)**

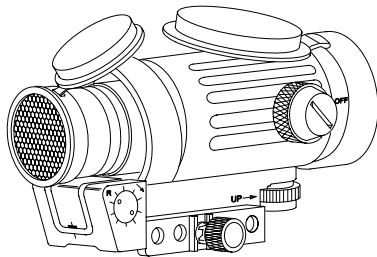

Distribution Statement A – Approved for public release; distribution is unlimited.

HEADQUARTERS, DEPARTMENT OF THE ARMY

28 FEBRUARY 2000

WARNING SUMMARY

This warning summary includes general safety precautions and instructions that must be understood and applied during the operation and maintenance of the Telescope to ensure personnel against injury, death, or long term health hazards. A summary of safety and hazardous material warnings that should be heeded in conduct of operation and maintenance is provided below.

LASER LIGHT – laser light hazard symbol indicates extreme danger for eyes from laser beams and reflections.

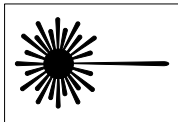

Use of the Telescope without laser filter is not eyesafe.

WARNING SUMMARY - Continued

Removal of the Signature Reduction Device (SRD) could lead to your detection by the enemy.

FIRST AID

For first aid procedures, refer to FM 21-11, First Aid for Soldiers.

LIST OF EFFECTIVE PAGES/WORK PACKAGES

Dates of issue for original and changed pages/work packages are:

Original... 0 ... 28 Feb 00

**TOTAL NUMBER OF PAGES FOR FRONT AND REAR MATTER IS 22 AND
TOTAL NUMBER OF WORK PACKAGES IS 36 CONSISTING OF THE
FOLLOWING:**

Page/WP No.	*Change No.	Page/WP No.	*Change No.
Title	0	i-x	0
a-b.....	0	WP 0001 00 - 0036 00	0
A	0	Index 1-8.....	0
B Blank	0		

*Zero in this column indicates an original page or work package.

TM 9-1240-415-13&P

HEADQUARTERS
DEPARTMENT OF THE ARMY
WASHINGTON, D.C., 28 FEBRUARY 2000

TECHNICAL MANUAL

**OPERATOR, UNIT, AND DIRECT SUPPORT MAINTENANCE MANUAL
INCLUDING REPAIR PARTS AND SPECIAL TOOLS LIST
FOR
TELESCOPE, STRAIGHT: M145
(1240-01-411-6350)**

REPORTING ERRORS AND RECOMMENDING IMPROVEMENTS

You can help improve this publication. If you find any mistakes or if you know of a way to improve the procedures, please let us know. Submit your DA Form 2028-2 (Recommended Changes to Equipment Technical Publications), through the Internet, on the Army Electronic Product Support (AEPS) website. The Internet address is <http://aeps.ria.army.mil>. If you need a password, scroll down and click on "ACCESS REQUEST FORM". The DA Form 2028 is located in the ONLINE FORMS PROCESSING section of the AEPS. Fill out the form and click on SUBMIT. Using this form on the AEPS will enable us to respond quicker to your comments and better manage the DA Form 2028 program. You may also mail, fax or email your letter, DA Form 2028, or DA Form 2028-2 direct to: Commander, U.S. Army Tank-automotive and Armaments Command, ATTN: AMSTA-LC-CIP-WT, Rock Island, IL 61299-7630. The email address is TACOM-TECH-PUBS@ria.army.mil. The fax number is DSN 793-0726 or Commercial (309) 782-0726.

DISTRIBUTION STATEMENT A – Approved for public release; distribution is unlimited.

TABLE OF CONTENTS

WP Sequence No.

WARNING SUMMARY

HOW TO USE THIS MANUAL

GENERAL INFORMATION..... 0001 00

CHAPTER 1 – DESCRIPTION AND THEORY OF OPERATION

Equipment Description and Data 0002 00

Theory of Operation 0003 00

CHAPTER 2 – OPERATOR INSTRUCTIONS

Description and Use of Operator Controls
and Indicators..... 0004 00

Assembly and Preparation for Use..... 0005 00

Operation Under Usual Conditions 0006 00

Operation Under Unusual Conditions 0007 00

TM 9-1240-415-13&P

CHAPTER 3 – UNIT TROUBLESHOOTING PROCEDURES

Troubleshooting Procedures 0008 00

CHAPTER 4 – DIRECT SUPPORT TROUBLESHOOTING PROCEDURES

Troubleshooting Procedures 0009 00

CHAPTER 5 – OPERATOR MAINTENANCE INSTRUCTIONS FOR THE M145 STRAIGHT TELESCOPE

Lens Cleaning Procedures 0010 00

Preparation for Storage or Shipment..... 0011 00

CHAPTER 6 – UNIT MAINTENANCE INSTRUCTIONS FOR THE M145 STRAIGHT TELESCOPE

Service Upon Receipt 0012 00

Preventive Maintenance Checks and

Services (PMCS) Introduction 0013 00

Preventive Maintenance Checks

and Services (PMCS) Procedures 0014 00

Battery Maintenance 0015 00

TM 9-1240-415-13&P

CHAPTER 6 – UNIT MAINTENANCE INSTRUCTIONS FOR THE M145 STRAIGHT TELESCOPE - Continued

Battery Cap O-ring Maintenance.....	0016 00
Lens Cover Maintenance	0017 00
Signature Reduction Device (SRD) and Laser Filter Maintenance.....	0018 00

CHAPTER 7 – DIRECT SUPPORT MAINTENANCE INSTRUCTIONS FOR THE M145 STRAIGHT TELESCOPE

Mount Assembly Maintenance	0019 00
Rubber Cover Maintenance	0020 00
Torque Limiting Knob/Shaft Maintenance.....	0021 00
Illustrated List of Manufactured Items	0022 00

CHAPTER 8 – SUPPORTING INFORMATION

References	0023 00
Maintenance Allocation Chart Introduction.....	0024 00
Maintenance Allocation Chart	0025 00
Repair Parts and Special Tools List Introduction	0026 00
M145 Straight Telescope with Case Repair Parts List	0027 00
M145 Sight Assembly Repair Parts List.....	0028 00

CHAPTER 8 – SUPPORTING INFORMATION - Continued

Battery Cap Assembly Repair Parts List.....	0029 00
Laser Filter Assembly/SRD Repair Parts List	0030 00
Mount Assembly Repair Parts List.....	0031 00
Case Assembly Repair Parts List.....	0032 00
National Stock Number (NSN) Index	0033 00
Part Number (P/N) Index	0034 00
Components of End Item (COEI) and Basic Issue	
Items (BII) Lists	0035 00
Expendable and Durable Items List	0036 00

INDEX

HOW TO USE THIS MANUAL

The safest, easiest, and best way to operate and maintain the Telescope is to use this manual. Learning to use this TM is as easy as reading through the next few pages of this section. Knowing what is in this manual and how to use it will save you time and work and will help you avoid exposing yourself to unnecessary hazards while performing your job.

So where do you start?

Right here, if this is the first time you are using this TM. Be sure to completely read this section on how to use this manual first. There's a lot of information here that you need to know.

Organization

This manual covers the operation and maintenance of the Telescope. The manual itself is divided into eight chapters, including supporting information. The eight chapters, and what they contain, are found in the Table of Contents in the front of this manual. For example, to learn about operating the Telescope, you would look in the table of contents and discover that Chapter 2 provides all pertinent information about the operation of the telescope. Since Chapter 2 covers a great deal of information, you will have to scan the chapter to find the specific information you will need.

In Chapter 8, you will find the supporting information. Each work package provides specific information that will assist you in performing the various operational and maintenance tasks. The work packages provide such information as additional references (i.e. other TMs or FMs), as in WP 0023 00, and Expendable and Durable Items List, as in WP 0036 00. Become familiar with all supporting information work packages and what they contain before beginning any operational or maintenance task.

HOW TO USE THIS MANUAL - Continued

Am I ready to use the TM?

If you've taken the time necessary to read this section, and are sure of the location and arrangement of the different sections of this TM, you are ready to begin. Remember, this TM has been arranged with you, the user, in mind. Your safety and ability to perform the operational and maintenance tasks in the most efficient manner possible hinge on your ability to perform and understand the information contained in this manual. If you fully understand the arrangement and purpose of this TM, and have taken the time to read through this section, you will have no trouble operating and maintaining the telescope in the manner for which it was designed.

OPERATOR

**TELESCOPE, STRAIGHT: M145
(NSN 1240-01-411-6350)**

GENERAL INFORMATION

SCOPE**Type of Manual**

Operator, Unit, and Direct Support Maintenance Manual including Repair Parts and Special Tools List.

Model Number and Equipment Name

M145 Straight Telescope with Mount.

SCOPE - Continued**Purpose of Equipment**

The Telescope is used for sighting targets on the M249 and M240B machine guns.

MAINTENANCE FORMS, RECORDS, AND REPORTS

Department of the Army forms and procedures used for equipment maintenance will be those prescribed in DA PAM 738-750, Functional User's Manual for the Army Maintenance Management System (TAMMS).

REPORTING EQUIPMENT IMPROVEMENT RECOMMENDATIONS (EIR)

If your Telescope or mount needs improvement, let us know. Send us an EIR. You, the user, are the only one who can tell us what you don't like about your equipment. Let us know why you don't like the design or performance. Put it on an SF 368 (Product Quality Deficiency Report). Mail it to us at Commander, U.S. Army Armament Research, Development and Engineering Center, ATTN: AMSTA-AR-QAW-A (R)/Customer Feedback Center, Rock Island, IL 61299-7300. We'll send you a reply.

CORROSION PREVENTION AND CONTROL (CPC)

Corrosion Prevention and Control (CPC) of Army materiel is a continuing problem. It is important that any corrosion problems with the telescope and mount be reported so that the problem can be corrected and improvements can be made to prevent the problem in future items.

CORROSION PREVENTION AND CONTROL (CPC) - Continued

While corrosion is typically associated with rusting of metals, it can also include deterioration of other materials such as rubber and plastic. Unusual cracking, softening, swelling, or breaking of these materials may be a corrosion problem.

If a corrosion problem is identified, it should be reported using SF 368, Product Quality Deficiency Report. Use of key words such as "corrosion", "rust", "deterioration", or "cracking" will ensure that the information is identified as a CPC problem.

The form should be sent to:

Commander
U.S. Army Armament Research, Development and Engineering Center
ATTN: AMSTA-AR-QAW-A (R)/Customer Feedback Center
Rock Island, IL 61299-7300

OZONE DEPLETING SUBSTANCES

Not applicable.

DESTRUCTION OF ARMY MATERIEL TO PREVENT ENEMY USE

Only your commanding officer can give the order to destroy materiel to prevent enemy use. Refer to TM 750-244-7.

PREPARATION FOR STORAGE OR SHIPMENT

Refer to WP 0011 00 for preparation for storage or shipment.

WARRANTY INFORMATION

The Telescope and Mount is warranted for 12 months from the date of delivery. The warranty starts on the date found in block 23 of DA Form 2408-9, Equipment Control Record. Report all defects to your supervisor, who will take appropriate action.

NOMENCLATURE CROSS REFERENCE LIST**Common Name****Official Nomenclature**

Laser Filter

Filter Assembly

Lens Cover

Front Cap Assembly

Lens Cover

Rear Cap Assembly

Picatinny Rail

MIL-STD 1913

Rotary Switch

Rotary Reticle Illumination Switch

Telescope

M145 Straight Telescope

**SUPPORTING INFORMATION FOR REPAIR PARTS, SPECIAL TOOLS,
TMDE, AND SUPPORT EQUIPMENT****Common Tools and Equipment**

For authorized common tools and equipment, refer to the Modified Table of Organization and Equipment (MTOE), CTA 50-970, Expendable/Durable Items (Except: Medical, Class V, Repair Parts, and Heraldic Items), or CTA 8-100, Army Medical Department Expendable/Durable Items, as applicable to your unit.

Special Tools, TMDE, and Support Equipment

Refer to WP0025 00 for a list of special tools that are used on this equipment. Also, refer to WP 0025 00 for the Maintenance Allocation Chart.

Repair Parts

Repair parts are listed and illustrated in supporting information work packages 0027 00 through 0032 00.

TM 9-1240-415-13&P

CHAPTER 1

**DESCRIPTION AND THEORY
OF OPERATION**

OPERATOR

**TELESCOPE, STRAIGHT: M145
(NSN 1240-01-411-6350)**

EQUIPMENT DESCRIPTION AND DATA

**EQUIPMENT CHARACTERISTICS, CAPABILITIES, AND FEATURES;
LOCATION AND DESCRIPTION OF MAJOR COMPONENTS;
EQUIPMENT DATA**

EQUIPMENT CHARACTERISTICS, CAPABILITIES, AND FEATURES

The telescope is a fixed 3.4 power, 28mm optical sight that has been designed to engage targets accurately out to 1200m range. The telescope weighs 24 oz (681 g) and is extremely rugged for rough field conditions. The telescope has an 8.2mm diameter exit pupil, which provides excellent vision in low light levels, i.e. dawn and dusk, and also allows for rapid target acquisition.

EQUIPMENT CHARACTERISTICS, CAPABILITIES, AND FEATURES - Continued

The zeroing adjustment increments in both windage and elevation are 2.5mm at 10 meter range for each detent (click of movement) and 5 in. (127mm) at 500 meter range.

The mount is designed to fit to the Picatinny rail. The telescope has an eye relief of approximately 3 in. (70mm). Eye relief is the distance between the eye and the sight's rear eyepiece lens.

The reticle pattern has a built-in trajectory compensation from 300m to 1200m range.

The reticle is illuminated by a battery and will last, at maximum brightness, for approximately seven days under continuous operation.

The optical housing of the telescope is purged with dry nitrogen to prevent moisture from fogging the internal optics.

WARNING

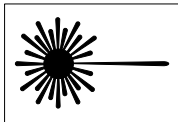

Use of the Telescope without laser filter is not eye safe.

Removal of the Signature Reduction Device (SRD) could lead to your detection by the enemy.

The front objective lens is fitted with a laser filter and a Signature Reduction Device (SRD).

These parts are removed by rotation in the counterclockwise direction.

**EQUIPMENT CHARACTERISTICS, CAPABILITIES, AND FEATURES -
Continued**

M145 STRAIGHT TELESCOPE

**FRONT-
SIGNATURE
REDUCTION
DEVICE (SRD)
AND LASER
FILTER**

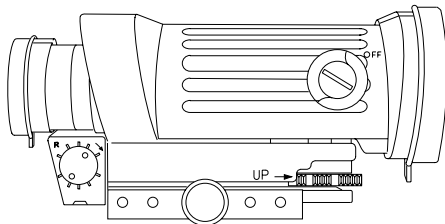

**BACK-
EYEPIECE
AND FIRER'S
VIEWING
END**

LOCATION AND DESCRIPTION OF MAJOR COMPONENTS

Elevation Adjustment Dial (1).

Moves the point of impact up or down when zeroing the telescope to the weapon.

Silver Lock (2). Locks and unlocks the elevation adjustment dial.

Front Lens Cover (3). Protects the front lens when sight is being transported or stored.

Windage Adjustment Dial (4).

Moves the point of impact to the left or right when zeroing the telescope to the weapon.

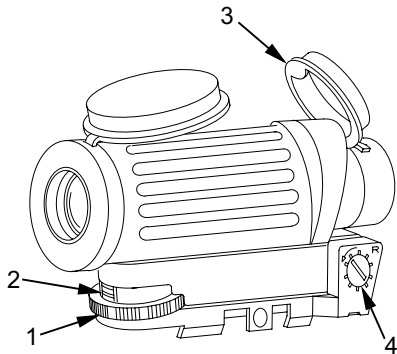

LOCATION AND DESCRIPTION OF MAJOR COMPONENTS - Continued

Rotary Switch (5). Turns the reticle light ON and OFF.

Battery Cap (10). Holds battery in telescope housing.

Rear Lens Cover (6). Protects the rear lens when sight is being transported or stored.

Torque Limiting Knob (7). Tightens the mount on the rail.

Mount (8). Assembly to which the telescope attaches.

Signature Reduction Device (SRD) (9). Eliminates glint and glare from reflective lens surface.

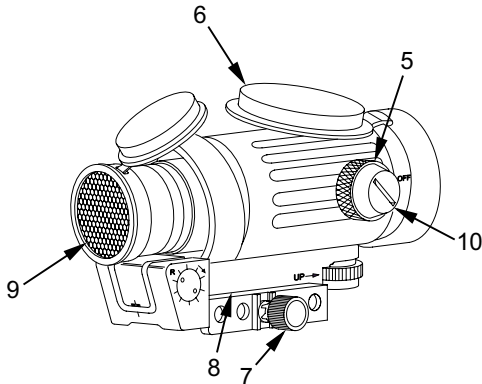

EQUIPMENT DATA

Optics: Anti-reflective coated lens system, 28mm clear objective, 3.4 magnification.

Overall Length: 7 in. (175mm)

Weight (M145): 24 oz (681 g)

Battery Life: 175 hr average (fresh battery). Sight is packed with a new battery from the factory.

NOTE

Two or more batteries stored together, without individual packaging, can short out and lose all their power.

END OF WORK PACKAGE

OPERATOR

**TELESCOPE, STRAIGHT: M145
(NSN 1240-01-411-6350)**

THEORY OF OPERATION

THEORY OF OPERATION

The Telescope is a telescopic sight. The telescope magnifies targets by 3-1/2 times or it appears to bring the shooter 3-1/2 times closer to the target. The telescope will show more clearly the strike of the round and allows more accurate shooting.

Lens covers protect the lenses when the sight is being transported or stored. The lens covers should always be kept closed when the sight is not in use.

THEORY OF OPERATION - Continued

The battery cap has an O-ring that keeps out moisture and dirt (see WP 0005 00, item 4).

With practice you may be able to keep both eyes open. With both eyes open you will be more aware of your surroundings and feel less strain on your eyes.

The telescope must remain matched with the same weapon, attached at the same slot in the rail system, or be re-zeroed.

END OF WORK PACKAGE

TM 9-1240-415-13&P

CHAPTER 2

OPERATOR INSTRUCTIONS

OPERATOR

**TELESCOPE, STRAIGHT: M145
(NSN 1240-01-411-6350)**

DESCRIPTION AND USE OF OPERATOR CONTROLS AND INDICATORS**CONTROLS AND INDICATORS**

CONTROLS AND INDICATORS**Elevation Adjustment Dial**

Used for zeroing the telescope to the weapon. The dial can only be rotated when the silver lock (1) is moved to the UP position. Turning the elevation adjustment dial (2) counterclockwise (in the direction of the arrow) one click moves the point of impact up 2.5mm at 10 meters.

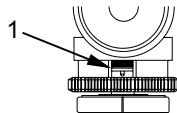
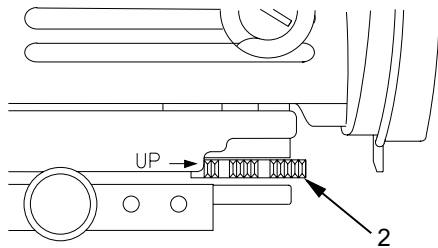
CONTROLS AND INDICATORS - Continued

Turning the elevation adjustment dial (2) clockwise (opposite direction to the arrow) one click moves the point of impact down 2.5mm at 10 meters. Ensure that the silver lock (1) is moved down to prevent any further movement of the elevation adjustment dial.

CONTROLS AND INDICATORS - Continued

Windage Adjustment Dial

Used when zeroing weapon. Turning windage adjustment dial (3) clockwise one click moves the point of impact left 2.5mm at 10 meters. Turning windage adjustment dial (3) counterclockwise one click moves the point of impact right 2.5mm at 10 meters.

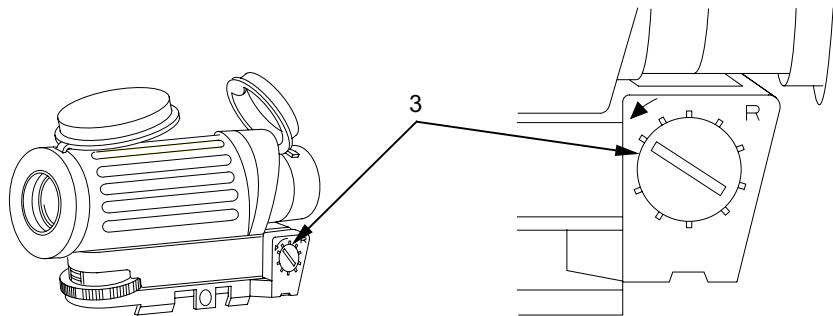

END OF WORK PACKAGE

OPERATOR

**TELESCOPE, STRAIGHT: M145
(NSN 1240-01-411-6350)**

ASSEMBLY AND PREPARATION FOR USE

INITIAL SETUP:

Materials/Parts

Battery (item 1, WP 0036 00)

ASSEMBLY AND PREPARATION FOR USE

Unpacking

1. Remove Telescope and Carrying Case (1) and Technical Manual (2) from shipping carton (3).
2. Save carton for telescope storage. Record serial number and warranty expiration date as per unit Standard Operating Procedure (SOP).

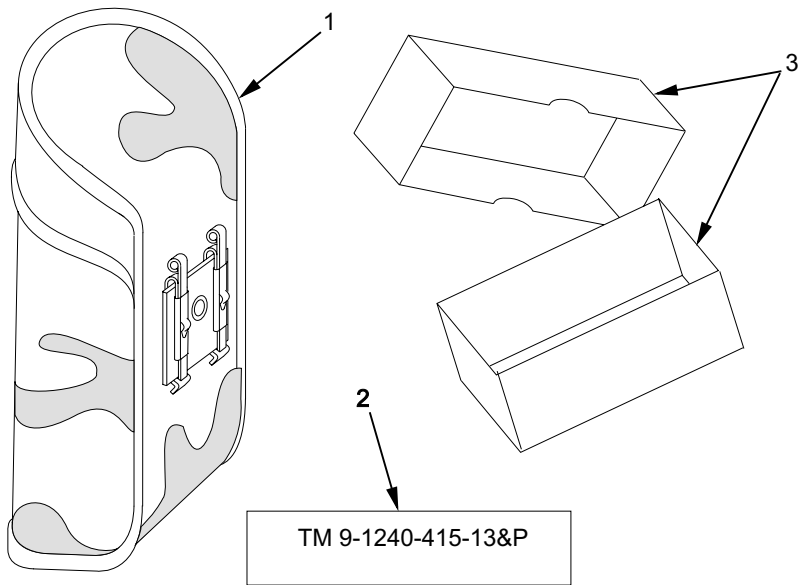

ASSEMBLY AND PREPARATION FOR USE - Continued**Installing and Checking Battery**

1. Remove battery cap (1) by turning it counterclockwise while holding the rotary switch (2) stationary.
2. Insert battery (3) (item 1, WP 0036 00) with positive (+) end to cap.

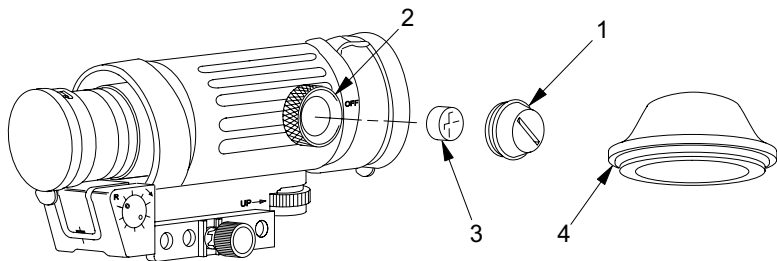

ASSEMBLY AND PREPARATION FOR USE - Continued**CAUTION**

Before installing battery cap (1), inspect threads on battery housing and battery cap to ensure that they are free of moisture and dirt and that the O-ring (4) in the battery cap is present. Failure to do so could result in loss of electrical power and shorten battery life.

Hand tighten battery cap. Using tools to tighten battery cap could damage equipment.

3. Re-install battery cap (1) by holding the rotary switch (2) stationary while turning battery cap clockwise until snug. Hand tighten only.

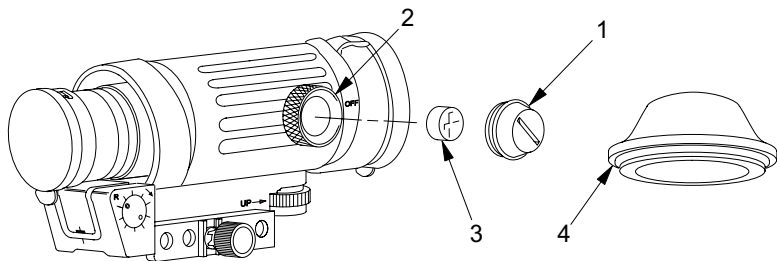

ASSEMBLY AND PREPARATION FOR USE - Continued

4. Open rear lens cover (5). Turn rotary switch (2) one click counterclockwise and look through rear lens. Verify that the reticle is illuminated. If not, replace battery. When finished, turn rotary switch to OFF position; then replace rear lens cover.

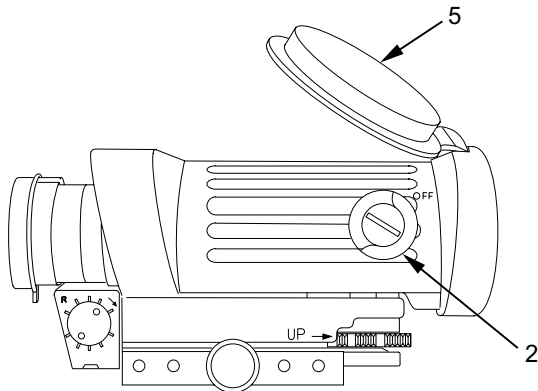

ROTARY
SWITCH TURNS
IN EITHER
DIRECTION WITH
NO STOP

Installing M145 Straight Telescope on M249 and M240B Machine Guns

CAUTION

Hand tighten torque limiting knob until you hear two clicks. Using tools to tighten mounting hardware could damage equipment.

NOTE

The Telescope mounts directly to the Picatinny rail on the M249 and M240B machine guns.

ASSEMBLY AND PREPARATION FOR USE - Continued**NOTE**

It will be necessary to adjust the position of the Telescope either backward or forward on the Picatinny rail in order to achieve the correct eye relief (distance of the eye from the back of the Telescope).

If the same sight is installed in the same position slot on the rail on the same weapon, re-zeroing is not required.

1. The torque limiting knob (1) should be turned counterclockwise just enough for the rail grabber to go over the rail. Do not force the torque limiting knob past its intended stop.
2. Mount the telescope firmly over the rail. Ensure that the mount is seated squarely over the rail.

3. Tighten the torque limiting knob (1) clockwise until two clicks are heard. Ensure that the mount is securely fastened before commencing eye relief adjustment.

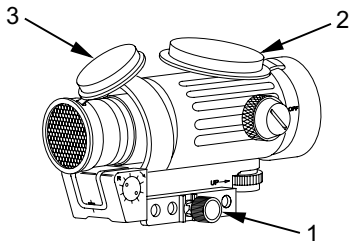

4. The telescope is now mounted to the weapon approximately 3 in. (70mm) in front of the firing eye.
5. Open rear lens cover (2) and front lens cover (3). Turn each cover inside out to stow the lens covers while the telescope is being used.

ASSEMBLY AND PREPARATION FOR USE - Continued

6. Assume a comfortable firing position and achieve a good stockweld (at trigger pull length) with both eyes closed. Open the sighting eye and compare the view through the telescope with the following examples:
 - a. If the target scene fills the telescope to provide the maximum field of view, the correct eye relief has been attained (see Figure 1). No further repositioning of the telescope on the Picatinny rail is required.

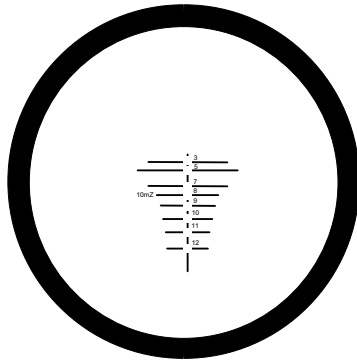

Figure 1. Maximum Field of View, Correct Eye Relief.

ASSEMBLY AND PREPARATION FOR USE - Continued

- b. If the target scene does not fill the sight's field of view, the telescope must be repositioned on the rail either forward or backward (see Figure 2).

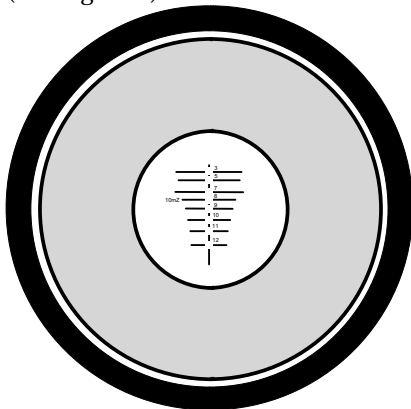

Figure 2. Limited Field of View, Incorrect Eye Relief.

7. The telescope must be repositioned for correct eye relief.
 - a. Loosen the torque limiting knob (1) and move the telescope in the appropriate direction (forward or backward) until you achieve the correct eye relief.
 - b. Repeat steps 1 through 5 until the correct field of view is obtained as shown in Figure 1.

END OF WORK PACKAGE

OPERATOR

**TELESCOPE, STRAIGHT: M145
(NSN 1240-01-411-6350)**

OPERATION UNDER USUAL CONDITIONS

OPERATING PROCEDURES

OPERATING PROCEDURES

Zeroing the M145 Straight Telescope on the M240B and M249 Machine Guns

1. Zeroing the telescope aligns the sight to the barrel of the machine gun so that point of aim equals point of impact.

NOTE

Adjustment of the Telescope is centered at the factory.

2. Open front lens cover (1) and rear lens cover (2). Turn each cover inside out to stow the lens covers while the telescope is being used.

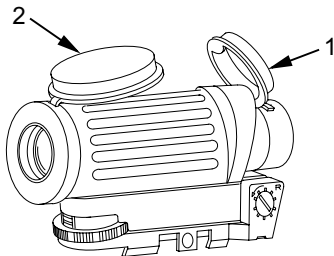

10 Meter Zeroing, Set the M145 Straight Telescope to Mechanical Zero

1. Adjust the telescope so that the weapon's barrel and optical sighting axis are in approximate alignment. The sighting axis will be approximately 2 to 3 in. (51 to 76 mm) above the machine gun barrel and therefore the strike of the bullet at 10m range will also be approximately 2 to 3 in. (51 to 76 mm) low without further zeroing adjustment.

WHEN GAPS ARE
EQUAL THE TELESCOPE
IS IN APPROXIMATE
ALIGNMENT

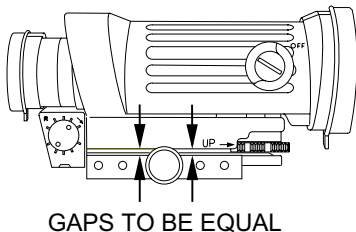

OPERATING PROCEDURES - Continued

2. To bring the strike of the bullet up, lift the silver lock (1) and rotate the elevation adjustment dial (2) counterclockwise (to the right) approximately one full turn.

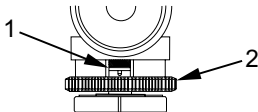

- Adjust the windage adjustment dial (3) to center the markings on the front of the telescope.

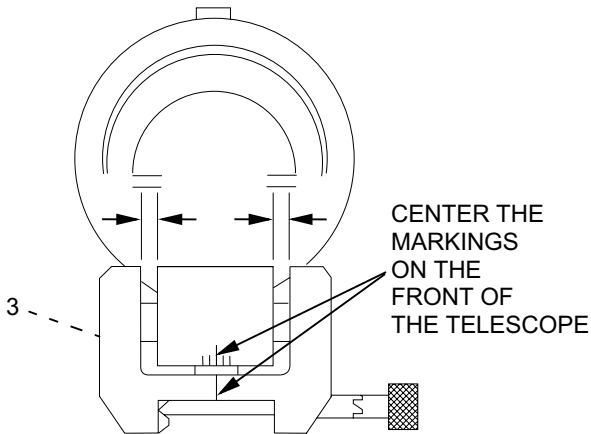

OPERATING PROCEDURES – Continued**NOTE**

Each click of the zeroing adjustments makes a 2.5mm movement of the point of impact at 10m.

4. Make final adjustments as follows:
 - a. To move the point of impact to the right, turn windage adjustment dial (3) counterclockwise with the arrow marked on the dial.
 - b. To move the point of impact to the left, turn windage adjustment dial (3) clockwise opposite to the arrow.
 - c. To move point of impact up, turn elevation adjustment dial (2) counterclockwise (right) in the direction of the arrow and UP marking.

- d. To move the point of impact down, turn elevation adjustment dial (2) clockwise (left) opposite to the arrow.

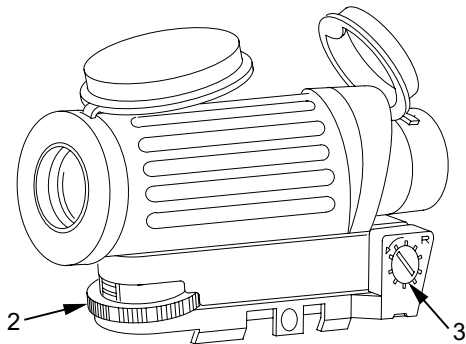

OPERATING PROCEDURES - Continued**10m Range Zeroing****NOTE**

In the zeroing process, groups of three single shot rounds are fired at a target. After each three rounds, the center of the group has to be determined.

The 10mZ (800) line is to be used with the M249 and M240B machine guns when firing the 10 meter exercise as part one of the qualifying course. The trajectory of the 5.56 and 7.62 round are equal at this aim point and distance to target.

1. Look through the telescope and align the reticle's 10mZ zeroing mark on the center base of the aiming points on the basic machine gun marksmanship target.

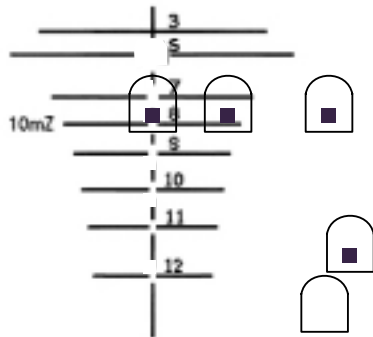

OPERATING PROCEDURES - Continued

2. Fire three single rounds loaded individually without making any telescope adjustments.
3. The three round shot group should be within a 4cm circle to establish the center of shot group in relation to the center base of the aiming paster.
4. Measure the amount of movement required left or right (windage) and up or down (elevation) to move the three round shot group onto the center of the aiming paster.
5. Windage correction: Upon completion, return to the firing line to make corrections to the weapon and re-fire a three round shot group to confirm zero.

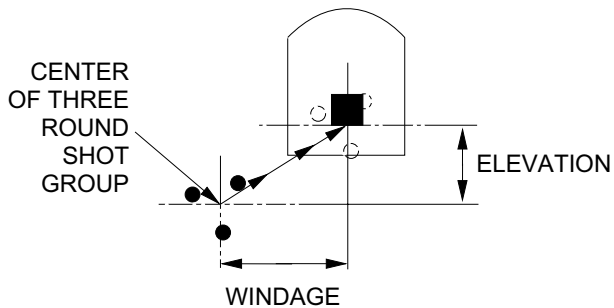

OPERATING PROCEDURES - Continued

6. Repeat steps 1 through 5 until the strike of the round is coincident with the center of the target. Close the silver lock down to prevent any further movement of the elevation adjustment dial. The telescope is now 10m zeroed.

Field Zero at 500m Range

1. Look through the telescope and align the reticle's 500m mark on the center of mass of the double "E" silhouette target.

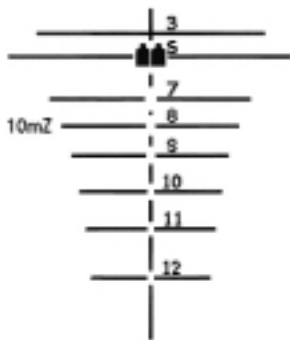

2. If firing a M240B weapon, fire a 6 to 9 round burst.
3. If firing a M249 weapon, fire a 5 to 7 round burst.
4. Observe impact of rounds.

OPERATING PROCEDURES - Continued

5. Determine direction of movement needed for impact (up or down, left or right).
6. Estimate or measure the amount of movement required to move the strike of the round to the center of the target (at 500 meters, 5 in. equals one click of adjustment in both windage and elevation).
7. Repeat steps 1 through 6 until the strike of the round is coincident with the center of the target. Close the silver lock down to prevent any further movement of the elevation adjustment dial. The telescope is now zeroed and ready for operational shooting.

Reticle

The vertical gap in the stadia lines is for estimating ranges. The height of gaps in the stadia lines represents a 60 in. (152.4 cm) high target at the range noted (i.e., 5, 7, 8, 9, 10, 11, or 1200 meters).

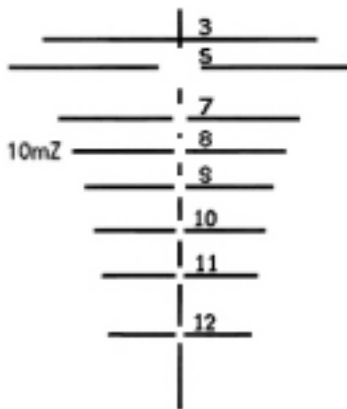

OPERATING PROCEDURES - Continued**Reticle Illumination****NOTE**

For low light operations, the reticle can be illuminated to show the 300m, 500m, 700m and 800m aiming marks.

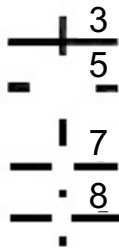

NOTE

Telescope is equipped with variable intensity light emitting diode (LED) illumination of the reticle. It has 10 positions: the OFF position and 9 positions for different reticle intensity settings.

1. To make reticle illumination adjustments, turn rotary switch (1) clockwise. The intensity of the illumination increases as the switch is turned.

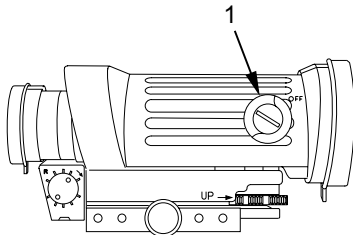

OPERATING PROCEDURES - Continued

2. Turn rotary switch (1) to OFF position when the telescope is being used during normal daylight or when illumination is not required.

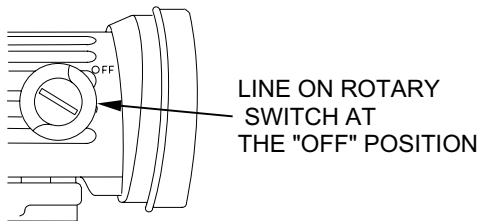
**NOTE**

Ensure the rotary switch is turned to the OFF position when not in use.

END OF WORK PACKAGE

OPERATOR

**TELESCOPE, STRAIGHT: M145
(NSN 1240-01-411-6350)**

OPERATION UNDER UNUSUAL CONDITIONS

**UNUSUAL ENVIRONMENTS AND WEATHER;
NUCLEAR, BIOLOGICAL, AND CHEMICAL (NBC) CONTAMINATION**

INITIAL SETUP:

Materials/Parts

Anti-fogging compound (item 3, WP 0036 00)
Lens paper (item 5, WP 0036 00)

References

WP 0010 00

UNUSUAL ENVIRONMENTS AND WEATHER

NOTE

Two or more batteries stored together, without individual packaging, can short out and lose all their power.

1. Extreme Cold. Extreme cold will shorten battery life. Keep spare batteries in a non-conductive container in your inner pockets to keep them warm. If the telescope is brought from cold to warm environment, wipe off condensation after it has warmed up.
2. Extreme Heat (Moist or Dry). No special procedures required.
3. Salt Air. No special procedures required.

4. Sea Spray. Ensure that battery cap is tight before exposing the telescope to water or sea spray. Hand tighten only. Keep lens caps closed when telescope is not being used. Clean lens (WP 0010 00) with lens paper (item 5, WP 0036 00) and dry telescope with a cloth as soon as possible after being exposed to water or sea spray.
5. Dust Storms and Sandstorms. Keep lens caps closed when telescope is not being used.
6. High Altitudes. No special procedures required.
7. Mud and Snow. Ensure that battery cap is tight before exposing the telescope to mud or snow. Hand tighten only. Keep lens caps closed when telescope is not being used. Clean lens (WP 0010 00) with lens paper (item 5, WP 0036 00) and dry telescope with a cloth as soon as possible after being exposed to mud or snow. Use anti-fogging compound (item 3, WP 0036 00). Try to acclimatize the telescope to the environment prior to mission usage to minimize fogging of external surfaces.

UNUSUAL ENVIRONMENTS AND WEATHER - Continued

8. Water. Ensure that battery cap is tight before immersing the telescope in water. Hand tighten only. Keep lens caps closed when telescope is not being used. Clean lens (WP 0010 00) with lens paper (item 5, WP 0036 00) and dry telescope with a cloth as soon as possible after being immersed in water. Use anti-fogging compound (item 3, WP 0036 00).

NUCLEAR, BIOLOGICAL, AND CHEMICAL (NBC) CONTAMINATION

All rubber must be removed before decontamination procedures using the M258A1 individual soldier's personal decontamination kit. The contaminated rubber material must be disposed of in accordance with the unit Standard Operating Procedure (SOP).

END OF WORK PACKAGE

TM 9-1240-415-13&P

CHAPTER 3

UNIT TROUBLESHOOTING

UNIT

**TELESCOPE, STRAIGHT: M145
(NSN 1240-01-411-6350)**

TROUBLESHOOTING

GENERAL, TROUBLESHOOTING PROCEDURES

INITIAL SETUP:

References

TB 43-0134

WP 0015 00

WP 0018 00

GENERAL

Troubleshooting Procedures lists common malfunctions that you may find with your telescope. Perform the tests, inspections, and corrective actions in the order they appear.

Troubleshooting Procedures cannot list all of the malfunctions that may occur, all of the tests and inspections needed to find the fault, or all of the corrective actions needed to correct the fault. If the equipment malfunction is not listed or the actions listed do not correct the fault, notify your armorer.

TROUBLESHOOTING PROCEDURES**NOTE**

The Telescope uses lithium-manganese dioxide batteries which, when depleted, are to be disposed of in accordance with technical bulletin, TB 43-0134, Battery Disposition and Disposal, paragraph 4-5, and local regulations and procedures (contact your local defense reutilization and marketing office (DRMO) for assistance). Certain states identify lithium-manganese dioxide batteries as hazardous waste; these states are currently Alaska, California, Minnesota, Rhode Island, and Washington.

TROUBLESHOOTING PROCEDURES - Continued**Table 1. Unit Troubleshooting Procedures.**

MALFUNCTION	TEST OR INSPECTION	CORRECTIVE ACTION
1. RETICLE DOES NOT ILLUMINATE.	<ol style="list-style-type: none">1. Battery installed incorrectly.2. Wrong type of battery.3. Dead battery.4. Battery not making good contact.	<p>Remove and reinstall battery (WP 0015 00).</p> <p>Replace battery (WP 0015 00).</p> <p>Replace battery (WP 0015 00).</p> <p>Remove battery cap and battery. Clean threads on battery cap and battery housing, then reinstall battery (WP 0015 00).</p>

Table 1. Unit Troubleshooting Procedures.

MALFUNCTION	TEST OR INSPECTION	CORRECTIVE ACTION
2. VIEW THROUGH THE TELESCOPE IS NOT CLEAR.	5. Battery cap spring missing. 6. Defective rotary switch. 1. Remove SRD and check for dirt or condensation on laser filter (WP 0018 00). 2. Remove laser filter and check for dirt or condensation on inner surface of laser filter or on the objective lens.	Notify armorer. Notify armorer. Remove dirt or condensation from laser filter. Remove dirt or condensation from inner surface of laser filter or from objective lens.

TROUBLESHOOTING PROCEDURES - Continued**Table 1. Unit Troubleshooting Procedures.**

MALFUNCTION	TEST OR INSPECTION	CORRECTIVE ACTION
3. ELEVATION OR WINDAGE ADJUSTMENT INOPERABLE.		Notify armorer.

END OF WORK PACKAGE

TM 9-1240-415-13&P

CHAPTER 4

DIRECT SUPPORT TROUBLESHOOTING

DIRECT SUPPORT

**TELESCOPE, STRAIGHT: M145
(NSN 1240-01-411-6350)**

TROUBLESHOOTING

GENERAL, TROUBLESHOOTING PROCEDURES

INITIAL SETUP:

References

TB 43-0134

WP 0020 00

WP 0021 00

GENERAL

Troubleshooting Procedures lists common malfunctions that you may find with your telescope. Perform the tests, inspections, and corrective actions in the order they appear in the table.

Troubleshooting Procedures cannot list all of the malfunctions that may occur, all of the tests and inspections needed to find the fault, or all of the corrective actions needed to correct the fault. If the equipment malfunction is not listed or the actions listed do not correct the fault, notify your armorer.

TROUBLESHOOTING PROCEDURES**NOTE**

The Telescope uses lithium-manganese dioxide batteries which, when depleted, are to be disposed of in accordance with technical bulletin, TB 43-0134, Battery Disposition and Disposal, paragraph 4-5, and local regulations and procedures (contact your local defense reutilization and marketing office (DRMO) for assistance). Certain states identify lithium-manganese dioxide batteries as hazardous waste; these states are currently Alaska, California, Minnesota, Rhode Island, and Washington.

TROUBLESHOOTING PROCEDURES - Continued**Table 1. Direct Support Troubleshooting Procedures.**

MALFUNCTION	TEST OR INSPECTION	CORRECTIVE ACTION
1. TORQUE LIMITING KNOB NOT SECURING SIGHT.		Re-adjust torque limiting knob (WP 0021 00).
2. TORQUE LIMITING KNOB NOT RATCHETING.		Re-adjust torque limiting knob (WP 0021 00).
3. TORQUE LIMITING SHAFT BENT.		Replace shaft (WP 0020 00, WP 0021 00).

END OF WORK PACKAGE

CHAPTER 5

**OPERATOR MAINTENANCE INSTRUCTIONS
FOR THE
M145 STRAIGHT TELESCOPE**

OPERATOR

**TELESCOPE, STRAIGHT: M145
(NSN 1240-01-411-6350)**

LENS CLEANING PROCEDURES

INITIAL SETUP:

Materials/Parts

Lens paper (item 5, WP 0036 00)

Optical lens cleaning compound (item 2, WP 0036 00)

LENS CLEANING PROCEDURES

1. Remove mud using optical lens cleaning compound (item 2, WP 0036 00) or by splashing water onto the lens.
2. Remove large particles from exposed lens surfaces by first blowing on the surfaces. Blow as much dust and dirt as possible from the exposed lens surfaces. Gather the center of a sheet of lens paper (item 5, WP 0036 00), and use the edges to brush dust from the front and back lens.
3. When all visible particles of dust and dirt have been removed, moisten a piece of lens paper (item 5, WP 0036 00) and gently wipe over the lens surface. Dry with clean lens paper (item 5, WP 0036 00).

END OF WORK PACKAGE

OPERATOR

**TELESCOPE, STRAIGHT: M145
(NSN 1240-01-411-6350)**

PREPARATION FOR STORAGE OR SHIPMENT

ADMINISTRATIVE STORAGE

INITIAL SETUP:

References

WP 0014 00

ADMINISTRATIVE STORAGE

Administrative storage of equipment issued to and used by the Army activities will have preventive maintenance performed in accordance with the PMCS table (WP 0014 00) before storing. When removing the equipment from administrative storage the PMCS should be performed to assure operational readiness.

END OF WORK PACKAGE

CHAPTER 6

**UNIT MAINTENANCE INSTRUCTIONS
FOR THE
M145 STRAIGHT TELESCOPE**

UNIT

**TELESCOPE, STRAIGHT: M145
(NSN 1240-01-411-6350)**

SERVICE UPON RECEIPT

SERVICE UPON RECEIPT

Inspect the equipment for damage incurred during shipment. If the equipment has been damaged, report the damage on an SF 361, Transportation Discrepancy Report.

Check the equipment against Figure 1, WP 0027 00 to see if the shipment is complete. Report all discrepancies in accordance with applicable service instructions (e.g. Army instructions, see DA PAM 738-750).

END OF WORK PACKAGE

UNIT

**TELESCOPE, STRAIGHT: M145
(NSN 1240-01-411-6350)**

**PREVENTIVE MAINTENANCE CHECKS AND SERVICES (PMCS)
INTRODUCTION**

GENERAL

GENERAL

Preventive Maintenance Checks and Services (PMCS) are performed to keep the equipment in operating condition. The checks are used to find, correct, or report problems. Unit members are to do the PMCS jobs as shown in WP 0014 00. PMCS are done every day the equipment is used, using WP 0014 00. Pay attention to WARNING and CAUTION statements. A WARNING means someone could be hurt. A CAUTION means equipment could be damaged.

GENERAL - Continued

1. BEFORE OPERATION. Perform your Before PMCS prior to the equipment performing its intended mission.
2. DURING OPERATION. Perform your During PMCS when the equipment is being used in its intended mission.
3. AFTER OPERATION. Be sure to perform your After PMCS after the equipment has performed its mission.

If your equipment fails to operate, troubleshoot. Report any deficiencies using the proper form; see DA PAM 738-750. If you cannot correct it yourself, notify your armorer.

Explanation of Columns

1. ITEM NUMBER column: Checks and services are numbered in disassembly sequence. This column shall be used as a source of item numbers for the "TM Number" column on DA Form 2404, Equipment Inspection and Maintenance Worksheet, in recording results of PMCS.
2. INTERVAL column: This column gives the designated interval when each check is to be performed.
3. MAN-HOUR column: Tells you how much time should be required for the procedure.
4. ITEM TO BE CHECKED OR SERVICED column: This column lists the items to be checked or serviced.
5. PROCEDURE column: This column contains a brief description of the procedure by which the check is to be performed. It contains all the information required to accomplish the checks and services.

GENERAL - Continued

6. EQUIPMENT NOT READY/AVAILABLE IF column: This column contains a brief statement of the condition (e.g. malfunction, shortage) that would cause the covered equipment to be less than fully ready to perform its assigned mission.

END OF WORK PACKAGE

UNIT

**TELESCOPE, STRAIGHT: M145
(NSN 1240-01-411-6350)**

**PREVENTIVE MAINTENANCE CHECKS AND SERVICES (PMCS),
INCLUDING LUBRICATION INSTRUCTIONS**

LUBRICATION INSTRUCTIONS, PMCS PROCEDURES

INITIAL SETUP:

References

WP 0015 00

LUBRICATION INSTRUCTIONS

No lubrication is required.

PMCS PROCEDURES

**Table 1. Preventive Maintenance Checks and Services for M145
Straight Telescope.**

ITEM NO.	INTERVAL	MAN-HOUR	ITEM TO BE CHECKED OR SERVICED	PROCEDURE	EQUIPMENT NOT READY/ AVAILABLE IF:
1	Before		Telescope	Look through the telescope. Inspect for visual obstruction of target image; dust, dirt, pits, or moisture on optical surfaces; loose or broken optical elements; and fogging/condensation.	These conditions are present and cannot be corrected by cleaning.

**Table 1. Preventive Maintenance Checks and Services for M145
Straight Telescope - Continued**

ITEM NO.	INTERVAL	MAN-HOUR	ITEM TO BE CHECKED OR SERVICED	PROCEDURE	EQUIPMENT NOT READY/ AVAILABLE IF:
2	Before		Telescope	Ensure that battery cap is present and that battery cap's threads are clean and undamaged. Inspect for O-ring and spring in battery cap.	Battery cap, spring, or O-ring missing. Unable to install battery cap.
3	Before		Telescope	Ensure that the 300m, 500m, 700m, and 800m marks in the reticle are illuminated when rotary switch is set to one of the operating positions. If necessary, replace battery (WP 0015 00) and check again.	The 300m, 500m, 700m, and 800m marks are not illuminated.

PMCS PROCEDURES - Continued

**Table 1. Preventive Maintenance Checks and Services for M145
Straight Telescope - Continued**

ITEM NO.	INTERVAL	MAN-HOUR	ITEM TO BE CHECKED OR SERVICED	PROCEDURE	EQUIPMENT NOT READY/ AVAILABLE IF:
4	Before		Mount	Check mount for damage that will prevent telescope from being installed.	Mount damaged in such a way that telescope cannot be installed.
5	Before		Telescope	Ensure both lens covers are present and can be snapped in place.	N/A

**Table 1. Preventive Maintenance Checks and Services for M145
Straight Telescope - Continued**

ITEM NO.	INTERVAL	MAN-HOUR	ITEM TO BE CHECKED OR SERVICED	PROCEDURE	EQUIPMENT NOT READY/ AVAILABLE IF:
6	Before		Torque Limiting Knob	Ensure torque limiting knob is torqued and tight.	Telescope is not properly attached and torqued to the rail.
7	Before		Torque Limiting Shaft	Ensure torque limiting shaft is not loose or bent.	Threads not functional and torque limiting shaft loose or bent.
8	Before		Telescope	Check entire telescope for loose or missing parts.	Parts not present or secured.

PMCS PROCEDURES - Continued

**Table 1. Preventive Maintenance Checks and Services for M145
Straight Telescope - Continued**

ITEM NO.	INTERVAL	MAN-HOUR	ITEM TO BE CHECKED OR SERVICED	PROCEDURE	EQUIPMENT NOT READY/ AVAILABLE IF:
9	Before		SRD and laser filter	Check that both are present.	SRD or laser filter not present.
10	Before		SRD and laser filter	Check for corrosion.	Corrosion interferes with operation.
11	During		Torque Limiting Knob	Ensure torque limiting knob is torqued and tight. After firing every 200 rounds, ensure torque limiting knob is tight by turning until you hear two clicks.	Telescope is not properly attached and torqued to the rail.

**Table 1. Preventive Maintenance Checks and Services for M145
Straight Telescope - Continued**

ITEM NO.	INTERVAL	MAN-HOUR	ITEM TO BE CHECKED OR SERVICED	PROCEDURE	EQUIPMENT NOT READY/ AVAILABLE IF:
12	After		Telescope	Look through the telescope. Inspect for visual obstruction of target image; dust, dirt, pits, or moisture on optical surfaces; loose or broken optical elements; and fogging/condensation.	These conditions are present and cannot be corrected by cleaning.
13	After		Telescope	Ensure that battery cap is present and that battery cap's threads are clean and undamaged. Inspect for O-ring and spring in battery cap.	Battery cap, spring, or O-ring missing. Unable to install battery cap.

PMCS PROCEDURES - Continued

**Table 1. Preventive Maintenance Checks and Services for M145
Straight Telescope - Continued**

ITEM NO.	INTERVAL	MAN-HOUR	ITEM TO BE CHECKED OR SERVICED	PROCEDURE	EQUIPMENT NOT READY/ AVAILABLE IF:
14	After		Mount	Check mount for damage that will prevent telescope from being installed.	Mount damaged in such a way that telescope cannot be installed.
15	After		Telescope	Ensure both lens covers are present and can be snapped in place.	N/A
16	After		Torque Limiting Knob	Ensure torque limiting knob is torqued and tight.	Telescope is not properly attached and torqued to the rail.

**Table 1. Preventive Maintenance Checks and Services for M145
Straight Telescope - Continued**

ITEM NO.	INTERVAL	MAN-HOUR	ITEM TO BE CHECKED OR SERVICED	PROCEDURE	EQUIPMENT NOT READY/ AVAILABLE IF:
17	After		Torque Limiting Shaft	Ensure torque limiting shaft is not loose or bent.	Threads not functional and torque limiting shaft loose or bent.
18	After		Telescope	Check entire telescope for loose or missing parts.	Parts not present or secured.

PMCS PROCEDURES - Continued**Table 1. Preventive Maintenance Checks and Services for M145
Straight Telescope - Continued**

ITEM NO.	INTERVAL	MAN-HOUR	ITEM TO BE CHECKED OR SERVICED	PROCEDURE	EQUIPMENT NOT READY/ AVAILABLE IF:
19	After		SRD and laser filter	Check that both are present.	SRD or laser filter not present.
20	After		SRD and laser filter	Check for corrosion.	Corrosion interferes with operation.

END OF WORK PACKAGE

UNIT

**TELESCOPE, STRAIGHT: M145
(NSN 1240-01-411-6350)**

BATTERY MAINTENANCE

REPAIR OR REPLACEMENT, TESTING

INITIAL SETUP:

Materials/Parts

Battery (item 1, WP 0036 00)

REPAIR OR REPLACEMENT**NOTE**

Ensure rotary switch is in the OFF position when the Telescope is not in use.

1. Remove battery cap (1) by turning it counterclockwise and holding the rotary switch (2) stationary.
2. Insert battery (3) (item 1, WP 0036 00) with positive (+) end to cap.

CAUTION

Before installing battery cap (1), inspect threads on battery housing and battery cap to ensure that they are free of moisture dirt and that the O-ring inside battery cap is present and properly seated. Failure to do so could result in loss of electrical power and shorten battery life.

3. Tighten battery cap (1) while holding the rotary switch (2) stationary.

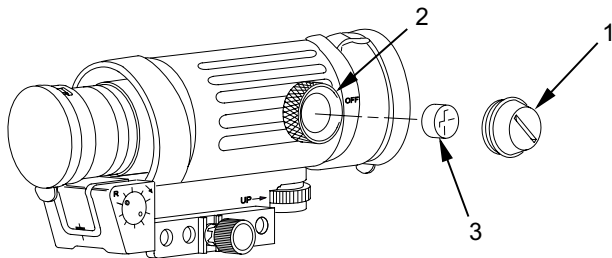

TESTING

Open rear lens cover (1). Turn rotary switch (2) clockwise and look through rear lens. Verify that reticle is illuminated. If not, replace battery (3). When finished, turn rotary switch to OFF position, then close rear lens cover.

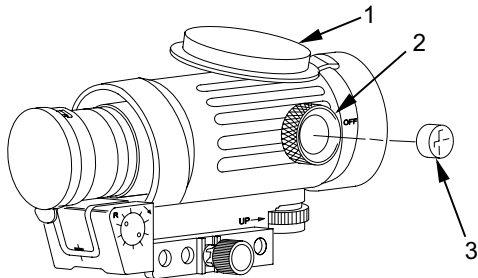

END OF WORK PACKAGE

UNIT

**TELESCOPE, STRAIGHT: M145
(NSN 1240-01-411-6350)**

**BATTERY CAP O-RING MAINTENANCE
REMOVAL, INSTALLATION**

REMOVAL

1. Remove battery cap (1) by turning it counterclockwise while holding the rotary switch stationary.
2. Remove O-ring (2) from battery cap (1).

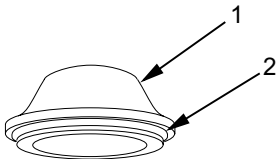

INSTALLATION

1. Install O-ring (2) onto battery cap (1). Ensure that the O-ring is properly seated.
2. Install battery cap (1) by turning it clockwise until tight while holding the rotary switch stationary.

END OF WORK PACKAGE

UNIT

**TELESCOPE, STRAIGHT: M145
(NSN 1240-01-411-6350)**

LENS COVER MAINTENANCE**REPAIR OR REPLACEMENT**

REPAIR OR REPLACEMENT

To remove the front objective lens cover, carefully pull the rubber cover plug (1) out of the socket (2), a small bulge and slot in the rubber ring around the top of the Signature Reduction Device (SRD). To remove the rear eyepiece lens cover, carefully pull the rubber cover plug (1) out of the socket (2), a small bulge and slot around the top part of the rubber cover at the back. To replace the lens covers, press the lens cover plug (1) into the socket (2) ensuring that the tabs are securely engaged in the socket.

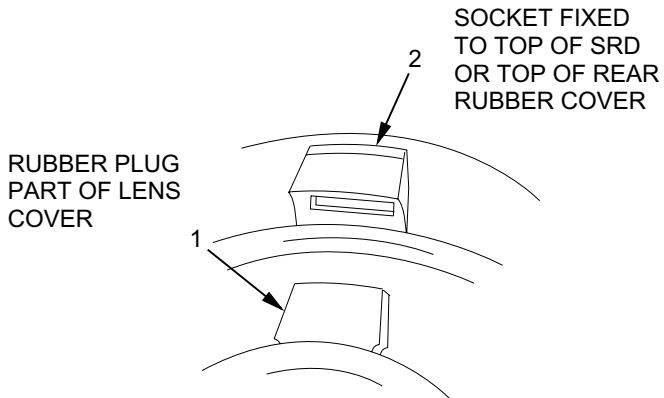
REPAIR OR REPLACEMENT - Continued**END OF WORK PACKAGE**

UNIT

**TELESCOPE, STRAIGHT: M145
(NSN 1240-01-411-6350)**

**SIGNATURE REDUCTION DEVICE (SRD) AND LASER FILTER
MAINTENANCE**

REMOVAL, CLEANING, INSTALLATION

INITIAL SETUP:

Materials/Parts

Optical lens cleaning compound (item 2, WP 0036 00)

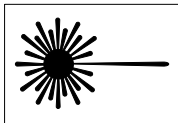
REMOVAL**WARNING**

Removal of the laser filter could result in the loss of your eyesight.

Removal of the SRD could lead to your detection by the enemy.

Remove the Signature Reduction Device (SRD) (1) and laser filter (2) by rotating in a counterclockwise direction. The laser filter has two slots to assist removal, if necessary.

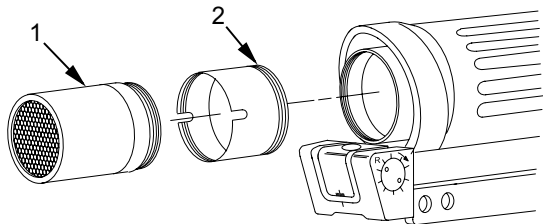

CLEANING

1. The SRD can be cleaned by running water through the honeycomb directly from a faucet. Shake out excess water and leave to dry.
2. Clean glass surfaces of laser filter (2) with lens cleaning compound (item 2, WP 0036 00).

INSTALLATION**CAUTION**

Do not tighten with any tools.

NOTE

The laser filter acts like a mirror; therefore, to minimize reflections, it is pointed down at a slight angle. The SRD is screwed on straight to the objective lens finger tight.

1. Install the laser filter (2) by screwing onto the front objective lens, finger tight only.
2. Install SRD. Turn clockwise until finger tight.

END OF WORK PACKAGE

CHAPTER 7

**DIRECT SUPPORT MAINTENANCE INSTRUCTIONS
FOR THE
M145 STRAIGHT TELESCOPE**

DIRECT SUPPORT

**TELESCOPE, STRAIGHT: M145
(NSN 1240-01-411-6350)**

MOUNT ASSEMBLY MAINTENANCE

REMOVAL, INSTALLATION

INITIAL SETUP:

Tools and Special Tools

Shop set, small arms: field maintenance basic, less power
(item 2, WP 0025 00)

5/32 in. hexagon bit socket (item 4, WP 0025 00)

REMOVAL

1. Turn the telescope (1) upside down and remove two screws (2) by using 3/8 in. drive ratchet handle with 5/32 in. hexagon bit socket (item 4, WP 0025 00).

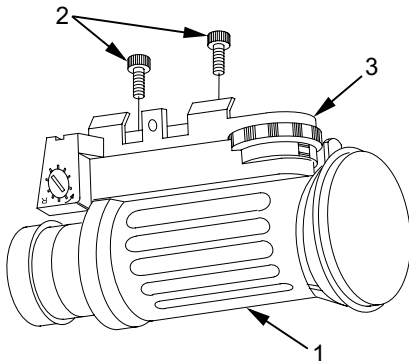

2. Separate the telescope (1) and the mount (3).

INSTALLATION

1. Ensure four shims (1) are in place on mount (2) before assembling to the telescope. Replace shims if defective. Any defective shim material remaining on the mount should be carefully scraped off and the surface cleaned. Remove shim backing paper from new shim(s) and attach the sticky surface to the mount in the positions shown.

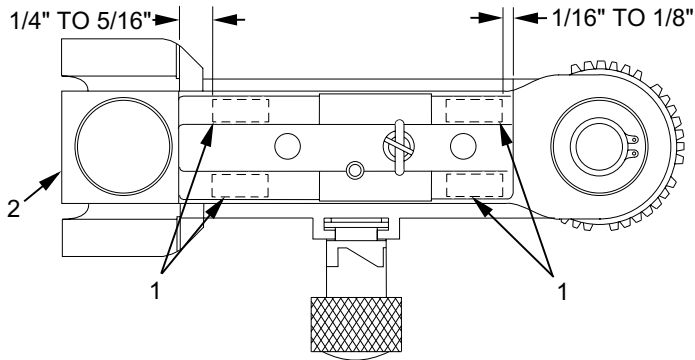

2. Hold the telescope (3) upside down and position the mount (2) on top. Place two screws (4) through the mount and tighten using a 3/8 in. drive torque wrench with 5/32 in. hexagon bit socket. Tighten to 60 to 90 in.-lb (6.83 to 10.24 N-m).

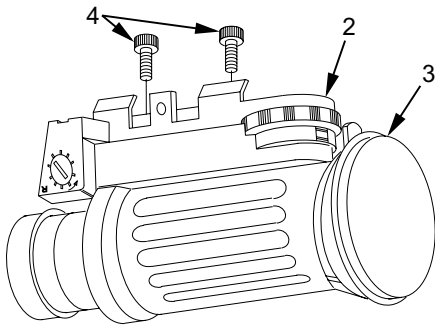

END OF WORK PACKAGE

DIRECT SUPPORT

**TELESCOPE, STRAIGHT: M145
(NSN 1240-01-411-6350)**

RUBBER COVER MAINTENANCE

REMOVAL, INSTALLATION

INITIAL SETUP:

References

WP 0017 00

WP 0018 00

WP 0019 00

REMOVAL**NOTE**

In case of decontamination, the rubber cover should be cut off the telescope and disposed of in accordance with unit Standard Operating Procedures (SOP).

1. Remove the Signature Reduction Device (SRD) and laser filter (WP 0018 00).
2. Remove the rear eyepiece lens cover (1) from the telescope (WP 0017 00). The complete eyepiece lens cover is pulled from the rubber cover.
3. Remove the telescope from the mount (WP 0019 00).

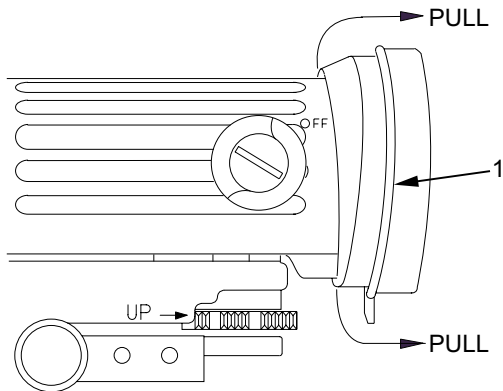

REMOVAL – Continued

4. The front portion of the rubber cover (2) is pulled over the front of the housing (3). The housing can now be pulled out of the rubber cover.

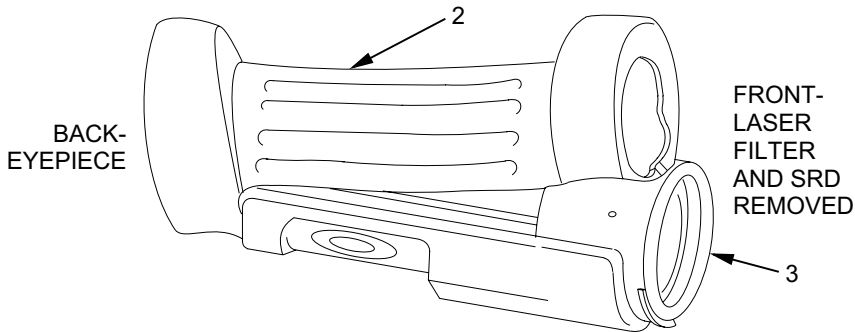

INSTALLATION

1. To increase the flexibility of the rubber cover (1), and to assist with its installation, the rubber cover should be pre-heated to approximately 120 °F (49 °C).
2. Install the rubber cover (1) by pressing the eyepiece end of the telescope (2) into the rubber cover.
3. The objective end of the rubber cover (1) is carefully pulled over the objective end of the telescope (2). Ensure that the rubber cover fits neatly around the housing.

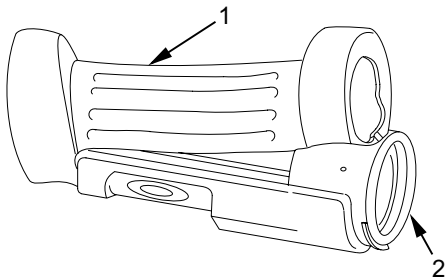
INSTALLATION - Continued

4. Install the rear eyepiece lens cover over the eyepiece end of the rubber cover (1) (WP 0017 00).
5. Install the mount on the telescope (WP 0019 00).
6. Install the laser filter and the SRD (WP 0018 00).

END OF WORK PACKAGE

DIRECT SUPPORT**TELESCOPE, STRAIGHT: M145
(NSN 1240-01-411-6350)****TORQUE LIMITING KNOB/SHAFT MAINTENANCE****DISASSEMBLY/ASSEMBLY**

INITIAL SETUP:**Tools and Special Tools**

Shop set, small arms: field
maintenance basic, less
power (item 2, WP 0025 00)
3/8 in. special ground socket
(item 3, WP 0025 00)

Materials/Parts

Loctite 680 (item 4,
WP 0036 00)
Sealing compound primer
(item 6, WP 0036 00)

DISASSEMBLY

1. Remove the dust protective plug (1) from the end of the nut (2). (This may permanently damage the dust protective plug).
2. Using 3/8 in. special ground socket (item 3, WP 0025 00), remove the nut (2).
3. Remove the spring (3) and torque knob (4). Unscrew torque nut (5). Remove torque nut and flat washer (6) from locking bar (7).
4. Remove the socket head screw (8) through the top of the mount (9) using a 5/64 in. key wrench. Remove the shaft (10) from the other side of the mount.

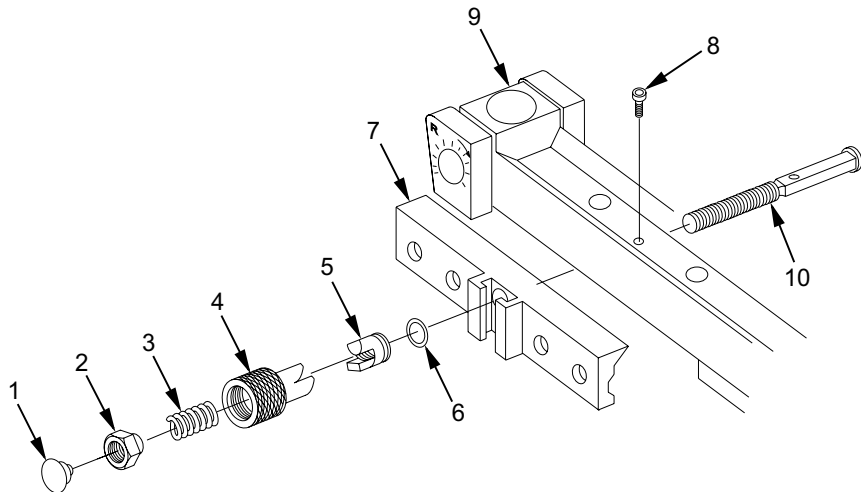

ASSEMBLY**NOTE**

Replace torque nut, dust protective plug, nut, socket head screw, and shaft after each disassembly as well as any defective parts (see WP 0031 00-1).

1. Insert the threaded portion of new shaft (1) through the round hole in the middle of the side of the mount (2), until the round end of the shaft fits flush into the hole.

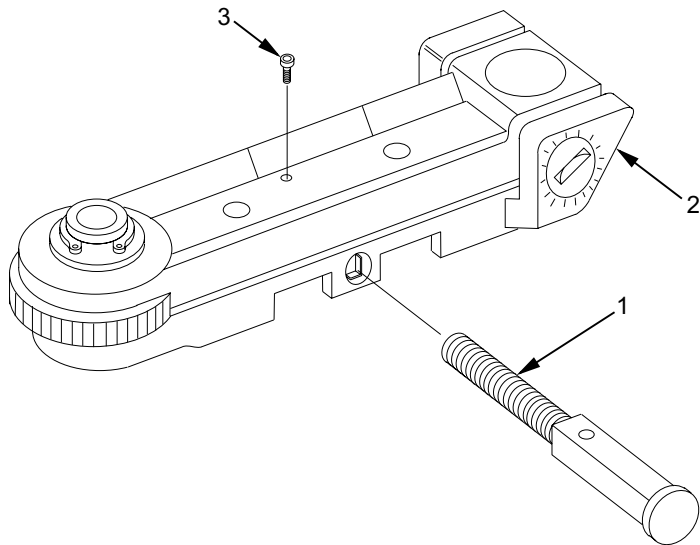

ASSEMBLY - Continued

2. Apply sealing compound primer (item 6, WP 0036 00) to threads of new socket head screw (3) and threaded end of shaft (1).
3. Apply Loctite 680 (item 4, WP 0036 00) to the screw threads of socket head screw (3).
4. Install socket head screw (3) and tighten with a 5/64 in. key wrench through the top of the mount (2) and into the shaft (1).
5. Place the flat washer (4) into the recess of the torque nut (5) and place them both into the slot of the locking bar (6). With the wide side of the locking bar at the top, screw the torque nut finger tight.
6. Fit the torque knob (7) onto the shaft (1) up to the torque nut (5) so that they mesh together. Push the spring (8) onto the shaft.

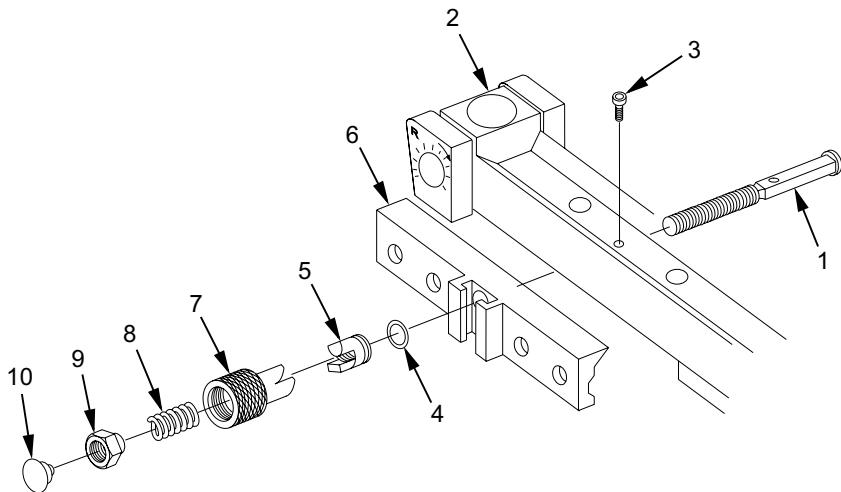

ASSEMBLY - Continued

7. Screw on new nut (9) so that the spring (8) locates over the protruding side of the nut. Tighten the nut until the torque knob (7) cannot ratchet. Place a drop of Loctite 680 (item 4, WP 0036 00) onto the threads of shaft (1). Turn the nut back off, over the Loctite 680, until the torque knob can ratchet. Back off the nut 3/4 of a turn.
8. Push on the new dust protective plug (10).

NOTE

Lay the mount on its side, with the shaft vertical. Sealing compound takes 24 hours to cure.

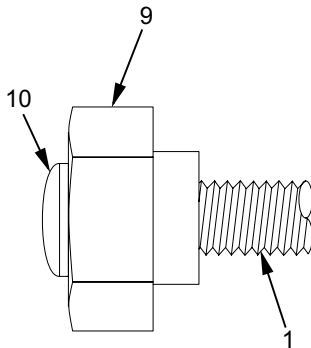

END OF WORK PACKAGE

0021 00-9/10 blank

DIRECT SUPPORT MAINTENANCE**TELESCOPE, STRAIGHT: M145
(NSN 1240-01-411-6350)****ILLUSTRATED LIST OF MANUFACTURED ITEMS**

INTRODUCTION**Scope**

This work package includes complete instructions for making items authorized to be manufactured or fabricated at the direct support maintenance level.

How to Use the Index of Manufactured Items

A part number index in alphanumeric order is provided for cross-referencing the part number of the item to be manufactured to the figure which covers fabrication criteria.

Explanation of the Illustrations of Manufactured Items

All instructions needed by maintenance personnel to manufacture the item are included on the illustrations. All bulk materials needed for manufacture of an item are listed by part number or specification number in a tabular list on the illustration.

INDEX OF MANUFACTURED ITEMS

Part Number

Figure Number

1

BEFORE
MODIFICATION

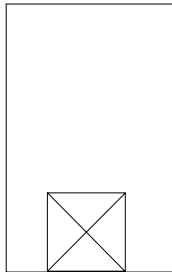

(SQUARE DRIVE
END)

AFTER
MODIFICATION

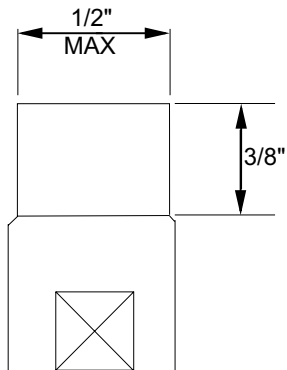

Figure 1. 3/8th Inch Special Ground Socket.

TM 9-1240-415-13&P

CHAPTER 8

SUPPORTING INFORMATION

OPERATOR, UNIT, AND DIRECT SUPPORT**TELESCOPE, STRAIGHT: M145
(NSN 1240-01-411-6350)****REFERENCES**

SCOPE

This work package lists all field manuals, forms, miscellaneous publications, technical bulletins, and technical manuals referenced in or required for use with this manual.

PUBLICATION INDEX

Consult DA Pam 25-30 for latest changes or revisions and for new publications relating to materiel covered in this manual.

FIELD MANUALS

FM 3-5	NBC Contamination
FM 3-87	Nuclear, Biological and Chemical (NBC) Reconnaissance and Decontamination Operations (How to Fight)
FM 21-11	First Aid for Soldiers
FM 23-68	Crew Served Machine Guns, 5.56mm, 7.62mm

FORMS

DA Form 2028	Recommended Changes to Publications and Blank Forms
DA Form 2404	Equipment Maintenance and Inspection Worksheet

FORMS - Continued

DA Form 2407	Maintenance Request
DA Form 2408-9	Equipment Control Record
SF 364	Report of Discrepancy
SF 368	Product Quality Deficiency Report

MISCELLANEOUS PUBLICATIONS

CTA 50-970	Expendable Items (Except Medical, Class V, Repair Parts, and Heraldic Items)
CTA 8-100	Army Medical Department Expendable/Durable Items.
DA Pam 25-30	Consolidated Index of Army Publications and Blank Forms
DA Pam 738-750	Functional User's Manual for the Army Maintenance Management System (TAMMS)

TECHNICAL BULLETINS

TB 43-0134

Battery Disposition and Disposal

TECHNICAL MANUALS

TM 750-244-7

Procedures for Destruction of Equipment to
Prevent Enemy Use

END OF WORK PACKAGE

OPERATOR, UNIT, AND DIRECT SUPPORT**TELESCOPE, STRAIGHT: M145
(NSN 1240-01-411-6350)****MAINTENANCE ALLOCATION CHART INTRODUCTION**

INTRODUCTION**The Army Maintenance System MAC**

This introduction provides a general explanation of all maintenance and repair functions authorized at various maintenance levels under the standard Army Maintenance System concept.

INTRODUCTION - Continued

The MAC (immediately following the introduction) designates overall authority and responsibility for the performance of maintenance functions on the identified end item of component. The application of the maintenance functions to the end item or component shall be consistent with the capacities and capabilities of the designated maintenance levels, which are shown on the MAC in column (4) as:

Unit – includes two subcolumns, C (operator/crew) and O (unit) maintenance.

Direct Support – includes an F subcolumn.

General Support – includes an H subcolumn.

Depot – includes a D subcolumn.

The tools and test equipment requirements (immediately following the MAC) list the tools and test equipment (both special tools and common tool sets) required for each maintenance function as referenced from the MAC.

The remarks (immediately following the tools and test equipment requirements) contain supplemental instructions and explanatory notes for a particular maintenance function.

Maintenance Functions

Maintenance functions are limited to and defined as follows:

1. **Inspect.** To determine the serviceability of an item by comparing its physical, mechanical, and/or electrical characteristics with established standards through examination (e.g., by sight, sound, or feel). This includes scheduled inspection and gagings and evaluation of cannon tubes.
2. **Test.** To verify serviceability by measuring the mechanical, pneumatic, hydraulic, or electrical characteristics of an item and comparing those characteristics with prescribed standards on a scheduled basis, i.e., load testing of lift devices and hydrostatic testing of pressure hoses.

INTRODUCTION - Continued

3. Service. Operations required periodically to keep an item in proper operating condition; e.g. to clean (includes decontaminate, when required), to preserve, to drain, to paint, or to replenish fuel, lubricants, chemical fluids, or gases. This includes scheduled exercising and purging of recoil mechanisms.
4. Adjust. To maintain or regulate, within prescribed limits, by bringing into proper position, or by setting the operating characteristics to specified parameters.
5. Align. To adjust specified variable elements of an item to bring about optimum or desired performance.

6. Calibrate. To determine and cause corrections to be made or to be adjusted on instruments of test, measuring, and diagnostic equipment used in precision measurement. Consists of comparisons of two instruments, one of which is a certified standard of known accuracy, to detect and adjust any discrepancy in the accuracy of the instrument being compared.
7. Remove/Install. To remove and install the same item when required to perform service or other maintenance functions. Install may be the act of emplacing, seating, or fixing into position a spare, repair part, or module (component or assembly) in a manner to allow the proper functioning of the equipment or system.
8. Replace. To remove an unserviceable item and install a serviceable counterpart in its place. "Replace" is authorized by the MAC and assigned maintenance level is shown as the third position code of the Source, Maintenance, and Recoverability (SMR) code.

INTRODUCTION - Continued

9. Repair. The application of maintenance services, including fault location/troubleshooting, removal/installation, disassembly/assembly procedures, and maintenance actions to identify troubles and restore serviceability to an item by correcting specific damage, fault, malfunction, or failure in a part, subassembly, module (component or assembly), end item, or system.

NOTE

The following definitions are applicable to the "Repair" maintenance function:

Services – Inspect, test, service, adjust, align, calibrate, and/or replace.

NOTE - CONTINUED

Fault location/troubleshooting – The process of investigating and detecting the cause of equipment malfunctioning; the act of isolating a fault within a system or Unit Under Test (UUT).

Disassembly/assembly – The step-by-step breakdown (taking apart) of a spare/functional group coded item to the level of its least component, that is assigned an SMR code for the level of maintenance under consideration (i.e., identified as maintenance significant).

Actions – Welding, grinding, riveting, straightening, facing, machining, and/or resurfacing.

INTRODUCTION - Continued

10. Overhaul. That maintenance effort (service/action) prescribed to restore an item to a completely serviceable/operational condition as required by maintenance standards in appropriate technical publications. Overhaul is normally the highest degree of maintenance performed by the Army. Overhaul does not normally return an item to like new condition.

11. Rebuild. Consists of those services/actions necessary for the restoration of unserviceable equipment to a like new condition in accordance with original manufacturing standards. Rebuild is the highest degree of materiel maintenance applied to Army equipment. The rebuild operation includes the act of returning to zero those age measurements (e.g. hours/miles) considered in classifying Army equipment/components.

Explanation of Columns in the MAC

Column (1) – Group Number. Column 1 lists FGC numbers, the purpose of which is to identify maintenance significant components, assemblies, subassemblies, and modules with the Next Higher Assembly (NHA).

Column (2) – Component/Assembly. Column (2) contains the item names of components, assemblies, subassemblies, and modules for which maintenance is authorized.

Column (3) – Maintenance Function. Column (3) lists the functions to be performed on the item listed in column (2). (For a detailed explanation of these functions refer to "Maintenance Functions" outlined above.)

INTRODUCTION - Continued

Column (4) – Maintenance Level. Column (4) specifies each level of maintenance authorized to perform each function listed in column (3), by indicating work time required (expressed as manhours in whole hours or decimals) in the appropriate subcolumn. This work time figure represents the active time required to perform that maintenance function at the indicated level of maintenance. If the number or complexity of the tasks within the listed maintenance function varies at different maintenance levels, appropriate work time figures are to be shown for each level. The work time figure represents the average time required to restore an item (assembly, subassembly, component, module, end item, or system) to a serviceable condition under typical field operating conditions. This time includes preparation time (including any necessary disassembly/assembly time), troubleshooting/fault location time, and quality assurance time in addition to the time required to perform the specific tasks identified for the maintenance functions authorized in the MAC. The symbol designations for the various maintenance levels are as follows:

- C – Operator or crew maintenance
- O – Unit maintenance
- F – Direct support maintenance
- L – Specialized repair activity (SRA)
- H – General support maintenance
- D – Depot maintenance

NOTE

The "L" maintenance level is not included in column (4) of the MAC. Functions to this level of maintenance are identified by a work time figure in the "H" column of column (4), and an associated reference code is used in the REMARKS column (6). This code is keyed to the remarks and the SRA complete repair application is explained there.

INTRODUCTION - Continued

Column (5) – Tools and Equipment Reference Code. Column (5) specifies, by code, those common tool sets (not individual tools), common Test, Measurement and Diagnostic Equipment (TMDE), and special tools, special TMDE and special support equipment required to perform the designated function. Codes are keyed to the entries in the tools and test equipment table.

Column (6) – Remarks Code. When applicable, this column contains a letter code, in alphabetical order, which is keyed to the remarks table entries.

Explanation of Columns in the Tools and Test Equipment Requirements

Column (1) – Tool or Test Equipment Reference Code. The tool or test equipment reference code correlates with a code used in column (5) of the MAC.

Column (2) – Maintenance Level. The lowest level of maintenance authorized to use the tool or test equipment.

Column (3) – Nomenclature. Name or identification of the tool or test equipment.

Column (4) – National Stock Number (NSN). The NSN of the tool or test equipment.

Column (5) – Tool Number. The manufacturer's part number, model number, or type number.

Explanation of Columns in the Remarks

Column (1) – Remarks Code. The code recorded in column (6) of the MAC.

Column (2) – Remarks. This column lists information pertinent to the maintenance function being performed as indicated in the MAC.

END OF WORK PACKAGE

OPERATOR, UNIT, AND DIRECT SUPPORT

**TELESCOPE, STRAIGHT: M145
(NSN 1240-01-411-6350)**

MAINTENANCE ALLOCATION CHART

Table 1. MAC for the M145 Straight Telescope

(1) GROUP NUMBER	(2) COMPONENT/ ASSEMBLY	(3) MAINTENANCE FUNCTION	(4) MAINTENANCE LEVEL				(5) TOOLS AND EQUIP- MENT REF CODE	(6) REMARKS CODE
			UNIT		DS	GS		
			C	O	F	H		
00	M145 STRAIGHT TELESCOPE WITH CASE	Inspect Service Repair	0.1 0.2	0.5	0.3		1	
01	M145 SIGHT ASSEMBLY	Inspect Service Repair Replace	0.1 0.2	0.2	0.4 0.2		1	A
0101	BATTERY CAP ASSEMBLY	Inspect Replace	0.1 0.1				1	A
0102	FILTER ASSEMBLY/ SRD	Inspect Replace	0.1 0.1					A

Table 1. MAC for the M145 Straight Telescope - Continued

(1) GROUP NUMBER	(2) COMPONENT /ASSEMBLY	(3) MAINTENANCE FUNCTION	(4) MAINTENANCE LEVEL				(5) TOOLS AND EQUIP- MENT REF CODE	(6) REMARKS CODE
			UNIT		DS	GS		
			C	O	F	H		
02	MOUNT ASSEMBLY	Inspect Service Repair Replace	0.2 0.1	0.1 0.5 0.5	0.1		1,2,3 1,3,4	A
03	CASE ASSEMBLY	Inspect Repair	0.1 0.1					

Table 2. Tools and Test Equipment for the M145 Straight Telescope.

TOOL OR TEST EQUIPMENT REF CODE	MAINTENANCE LEVEL	NOMENCLATURE	NATIONAL STOCK NUMBER	TOOL/PART NUMBER
1	O	Tool Kit, Small Arms Repairman	5180-00-357-7770	SC 5180-95-A07
2	F	Shop Set, Small Arms: Field Maintenance Basic, Less Power	4933-00-754-0664	SC 4933-95-A11
3	F	3/8 Special Ground Socket (see WP 0022 00)	Make from 5120-00-227-6702	A-A-1404
4	F	3/8 in. Drive, 5/32 in. Hexagon Bit Socket	5120-01-398-7922	9-46669

Figure 3. Remarks for M145 Straight Telescope.

REMARKS CODE	REMARKS
A	Preventive Maintenance Checks and Services (PMCS)

END OF WORK PACKAGE

UNIT AND DIRECT SUPPORT**TELESCOPE, STRAIGHT: M145
(NSN 1240-01-411-6350)****REPAIR PARTS AND SPECIAL TOOLS LIST INTRODUCTION****SCOPE, GENERAL**

SCOPE

This RPSTL lists and authorizes spares and repair parts; special tools; special test, measurement, and diagnostic equipment (TMDE); and other special support equipment required for the performance of unit and direct support maintenance of the Telescope. It authorizes the requisitioning, issue, and disposition of spares, repair parts, and special tools as indicated by the Source, Maintenance, and Recoverability (SMR) codes.

GENERAL

In addition to the Introduction work package, this RPSTL is divided into the following work packages.

1. **Repair Parts List Work Packages.** Work packages containing lists of spares and repair parts authorized by this RPSTL for use in the performance of maintenance. These work packages also include parts which must be removed for replacement of the authorized parts. Parts lists are composed of functional groups in ascending alphanumeric sequence, with the parts in each group listed in ascending figure and item number sequence. Sending units, brackets, filters, and bolts are listed with the component they mount on. Bulk materials are listed by item name in FIG. BULK at the end of the work packages. Repair parts kits are listed separately in their own functional group and work package. Repair parts for reparable special tools are also listed in a separate work package. Items listed are shown on the associated illustrations.

2. **Special Tools List Work Packages.** Work packages containing lists of special tools, special TMDE, and special support equipment authorized by this RPSTL (as indicated by Basis of Issue (BOI) information in the DESCRIPTION AND USABLE ON CODE (UOC) column). Tools that are components of common tool sets and/or Class VII are not listed.

3. **Cross-Reference Indexes Work Packages.** There are two cross-reference indexes work packages in this RPSTL: the National Stock Number (NSN) Index Work package and the Part Number (P/N) Index Work Package. The National Stock Number Index work package refers you to the figure and item number. The Part Number Index work package refers you to the figure and item number.

EXPLANATION OF COLUMNS IN THE REPAIR PARTS LIST AND SPECIAL TOOLS LIST WORK PACKAGES

ITEM NO. (Column (1)). Indicates the number used to identify items called out in the illustration.

EXPLANATION OF COLUMNS IN THE REPAIR PARTS LIST AND SPECIAL TOOLS LIST WORK PACKAGES – CONTINUED

SMR CODE (Column (2)). The SMR code containing supply/requisitioning information, maintenance level authorization criteria, and disposition instruction, as shown in the following breakout:

<u>Source Code</u>	<u>Maintenance Code</u>	<u>Recoverability Code</u>	
<u>XX</u>	<u>XX</u>	<u>X</u>	
First two positions: How to get an item.	Third position: Who can install, replace, or use the item.	Fourth position: Who can do complete repair* on the item.	Fifth position: Who determines disposition action on unserviceable items.

*Complete Repair: Maintenance capacity, capability, and authority to perform all corrective maintenance tasks of the "Repair" function in a use/user environment in order to restore serviceability to a failed item.

Source Code. The source code tells you how to get an item needed for maintenance, repair, or overhaul of an end item/equipment. Explanations of source codes follow:

Source Code**Application/Explanation**

PA
PB
PC
PD
PE
PF
PG

Stock items; use the applicable NSN to requisition/request items with these source codes. They are authorized to the level indicated by the code entered in the third position of the SMR code.

NOTE

Items coded PC are subject to deterioration.

EXPLANATION OF COLUMNS IN THE REPAIR PARTS LIST AND SPECIAL TOOLS LIST WORK PACKAGES – CONTINUED**Source Code****Application/Explanation****KD****KF****KB**

Items with these codes are not to be requested/requisitioned individually. They are part of a kit which is authorized to the maintenance level indicated in the third position of the SMR code. The complete kit must be requisitioned and applied.

MO - Made at unit level**MF** - Made at DS level**MH** - Made at GS level**ML** - Made at SRA**MD** - Made at depot

Items with these codes are not to be requisitioned/requested individually. They must be made from bulk material which is identified by the P/N in the DESCRIPTION AND USABLE ON CODE (UOC) column and listed in the bulk material group work package of the RPSTL. If the item is authorized to you by the third position code of the SMR code, but the source code indicates it is made at a higher level, order the item from the higher level of maintenance.

Source Code**Application/Explanation**

AO - Assembled by
unit level

AF - Assembled by
DS level

AH - Assembled by
GS level

AL - Assembled by
SRA

AD - Assembled by
depot

XA

XB

Items with these codes are not to be requisitioned/requested individually. The parts that make up the assembled item must be requisitioned or fabricated and assembled at the level of maintenance indicated by the source code. If the third position of the SMR code authorizes you to replace the item, but the source code indicates the item is assembled at a higher level, order the item from the higher level of maintenance.

Do not requisition an "XA" coded item. Order the higher assembly. (Refer to NOTE below.)

If an item is not available from salvage, order it using the CAGEC and P/N.

EXPLANATION OF COLUMNS IN THE REPAIR PARTS LIST AND SPECIAL TOOLS LIST WORK PACKAGES – CONTINUED**Source Code****Application/Explanation****XC**

Installation drawings, diagrams, instruction sheets, field service drawings; identified by manufacturer's P/N.

XD

Item is not stocked. Order an XD-coded item through normal supply channels using the CAGEC and P/N given, if no NSN is available.

NOTE

Cannibalization or controlled exchange, when authorized, may be used as a source of supply for items with the above source codes, except for those items source coded "XA" or those aircraft support items restricted by requirements of AR 750-1.

Maintenance Code. Maintenance codes tell you the level(s) of maintenance authorized to use and repair support items. The maintenance codes are entered in the third and fourth positions of the SMR code as follows:

Third Position. The maintenance code entered in the third position tells you the lowest maintenance level authorized to remove, replace, and use the item. The maintenance code entered in the third position will indicate authorization to one of the following levels of maintenance:

EXPLANATION OF COLUMNS IN THE REPAIR PARTS LIST AND SPECIAL TOOLS LIST WORK PACKAGES – CONTINUED

<u>Maintenance Code</u>	<u>Application/Explanation</u>
C	— Crew or operator maintenance done within unit maintenance.
O	— Unit level maintenance can remove, replace, and use the item.
F	— Direct support maintenance can remove, replace, and use the item.
H	— General support maintenance can remove, replace, and use the item.
L	— Specialized repair activity can remove, replace, and use the item.
D	— Depot can remove, replace, and use the item.

Fourth Position. The maintenance code entered in the fourth position tells you whether or not the item is to be repaired and identifies the lowest maintenance level with the capability to do complete repair (perform all authorized repair functions).

NOTE

Some limited repair may be done on the item at a lower level of maintenance, if authorized by the Maintenance Allocation Chart (MAC) and SMR codes.

EXPLANATION OF COLUMNS IN THE REPAIR PARTS LIST AND SPECIAL TOOLS LIST WORK PACKAGES – CONTINUED

<u>Maintenance Code</u>		<u>Application/Explanation</u>
O	—	Unit is the lowest level that can do complete repair of the item.
F	—	Direct support is the lowest level that can do complete repair of the item.
H	—	General support is the lowest level that can do complete repair of the item.
L	—	Specialized repair activity is the lowest level that can do complete repair of the item.
D	—	Depot is the lowest level that can do complete repair of the item.

Maintenance Code**Application/Explanation**

Z	—	Nonreparable. No repair is authorized.
B	—	No repair is authorized. No parts or special tools are authorized for the maintenance of a "B" coded item. However, the item may be reconditioned by adjusting, lubricating, etc., at the user level.

Recoverability Code. Recoverability codes are assigned to items to indicate the disposition action on unserviceable items. The recoverability code is shown in the fifth position of the SMR code as follows:

Recoverability Code**Application/Explanation**

Z	—	Nonreparable item. When unserviceable, condemn and dispose of the item at the level of maintenance shown in the third position of the SMR code.
----------	---	---

<u>Recoverability Code</u>	<u>Application/Explanation</u>
O	— Reparable item. When uneconomically repairable, condemn and dispose of the item at the unit level.
F	— Reparable item. When uneconomically repairable, condemn and dispose of the item at the direct support level.
H	— Reparable item. When uneconomically repairable, condemn and dispose of the item at the general support level.
D	— Reparable item. When beyond lower level repair capability, return to depot. Condemnation and disposal of item are not authorized below depot level.
L	— Reparable item. Condemnation and disposal not authorized below Specialized Repair Activity (SRA).
A	— Item requires special handling or condemnation procedures because of specific reasons (such as precious metal content, high dollar value, critical material, or hazardous material). Refer to appropriate manuals/directives for specific instructions.

NSN (Column (3)). The NSN of the item is listed in this column.

CAGEC (Column (4)). The Contractor and Government Entity Code (CAGEC) is a five-digit code which is used to identify the manufacturer, distributor, or Government agency/activity that supplies the item.

PART NUMBER (Column (5)). Indicates the primary number used by the manufacturer (individual, company, firm, corporation, or Government activity), which controls the design and characteristics of the item by means of its engineering drawings, specifications, standards, and inspection requirements to identify an item or range of items.

NOTE

When you use an NSN to requisition an item, the item you receive may have a different P/N from the number listed.

EXPLANATION OF COLUMNS IN THE REPAIR PARTS LIST AND SPECIAL TOOLS LIST WORK PACKAGES – CONTINUED

DESCRIPTION AND USABLE ON CODE (UOC) (Column (6)). This column includes the following information:

1. The federal item name, and when required, a minimum description to identify the item.
2. P/Ns of bulk materials are referenced in this column in the line entry to be manufactured or fabricated.
3. Hardness Critical Item (HCI). A support item that provides the equipment with special protection from electromagnetic pulse (EMP) damage during a nuclear attack.
4. The statement END OF FIGURE appears just below the last item description in column (6) for a given figure in both the repair parts list and special tools list work packages.

QTY (Column (7)). The QTY (quantity per figure) column indicates the quantity of the item used in the breakout shown on the illustration/figure, which is prepared for a functional group, subfunctional group, or an assembly. A "V" appearing in this column instead of a quantity indicates that the quantity is variable and quantity may change from application to application.

EXPLANATION OF CROSS-REFERENCE INDEXES WORK PACKAGES FORMAT AND COLUMNS

1. National Stock Number (NSN) Index Work Package.

STOCK NUMBER Column. This column lists the NSN in National item identification number (NIIN) sequence. The NIIN consists of the last nine digits of the NSN.

 NSN
(e.g., 5385-01-574-1476)
 NIIN

When using this column to locate an item, ignore the first four digits of the NSN. However, the complete NSN should be used when ordering items by stock number.

**EXPLANATION OF CROSS-REFERENCE INDEXES WORK PACKAGES
FORMAT AND COLUMNS - Continued**

FIG. Column. This column lists the number of the figure where the item is identified/located. The figures are in numerical order in the repair parts list and special tools list work packages.

ITEM Column. The item number identifies the item associated with the figure listed in the adjacent FIG. column. This item is also identified by the NSN listed on the same line.

2. **Part Number (P/N) Index Work Package.** P/Ns in this index are listed in ascending alphanumeric sequence (vertical arrangement of letter and number combinations which places the first letter or digit of each group in order A through Z, followed by the numbers 0 through 9 and each following letter or digit in like order).

PART NUMBER column. Indicates the P/N assigned to the item.

FIG. Column. This column lists the number of the figure where the item is identified/located in the repair parts and special tools list work packages.

ITEM Column. The item number is the number assigned to the item as it appears in the figure referenced in the adjacent figure number column.

SPECIAL INFORMATION

USABLE ON CODE (UOC). The UOC appears in the lower left corner of the Description Column heading. Usable on codes are shown as "UOC: ..." in the Description Column (justified left) on the first line under the applicable item/nomenclature. Uncoded items are applicable to all models.

Fabrication Instructions. Bulk materials required to manufacture items are listed in the bulk material functional group of this RPSTL. Part numbers for bulk material are also referenced in the Description Column of the line item entry for the item to be manufactured/fabricated. Detailed fabrication instructions for items source coded to be manufactured or fabricated are found in WP 0022 00.

SPECIAL INFORMATION - Continued

Index Numbers. Items which have the word BULK in the figure column will have an index number shown in the item number column. This index number is a cross-reference between the NSN / P/N index work packages and the bulk material list in the repair parts list work package.

HOW TO LOCATE REPAIR PARTS

1. When NSNs or P/Ns Are Not Known.

First. Using the table of contents, determine the assembly group to which the item belongs. This is necessary since figures are prepared for assembly groups and subassembly groups, and lists are divided into the same groups.

Second. Find the figure covering the functional group or the subfunctional group to which the item belongs.

Third. Identify the item on the figure and note the number(s).

Fourth. Look in the repair parts list work packages for the figure and item numbers. The NSNs and part numbers are on the same line as the associated item numbers.

2. When NSN Is Known.

First. If you have the NSN, look in the STOCK NUMBER column of the NSN index work package. The NSN is arranged in NIIN sequence. Note the figure and item number next to the NSN.

Second. Turn to the figure and locate the item number. Verify that the item is the one you are looking for.

HOW TO LOCATE REPAIR PARTS - Continued

3. When P/N Is Known.

First. If you have the P/N and not the NSN, look in the PART NUMBER column of the P/N index work package. Identify the figure and item number.

Second. Look up the item on the figure in the applicable repair parts list work package.

ABBREVIATIONS

Not applicable.

END OF WORK PACKAGE

UNIT AND DIRECT SUPPORT MAINTENANCE

**TELESCOPE, STRAIGHT: M145
(NSN 1240-01-411-6350)**

M145 STRAIGHT TELESCOPE WITH CASE

REPAIR PARTS LIST

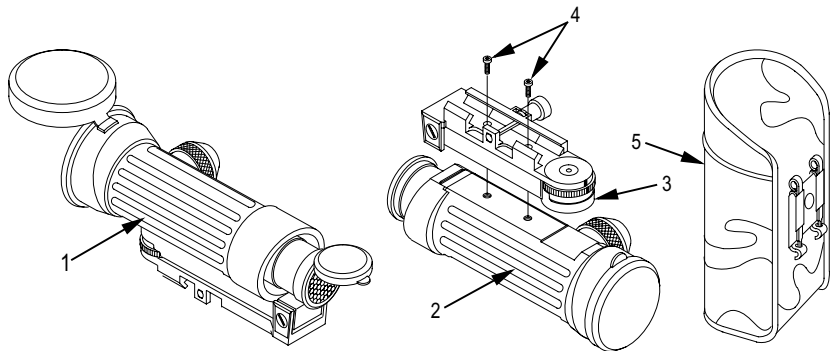

Figure 1. M145 Straight Telescope
with Case.

(1)	(2)	(3)	(4)	(5)	(6)	(7)
ITEM NO.	SMR CODE	NSN	CAGEC	PART NUMBER	DESCRIPTION AND USABLE ON CODE (UOC)	QTY
					GROUP 00	
					FIG. 1 TELESCOPE WITH CASE, STRAIGHT, M145	
1	AFFFF		36126	901581-001	SIGHT ASSEMBLY, M145 (For assembly breakdown see Figure 2).....	1
2	PAFFF	1240-21-920-2783	36126	901614-001	.SIGHT	1
3	PAFFF	1240-21-920-2492	36126	901615-001	.MOUNT ASSEMBLY (For assembly breakdown see Figure 5).....	1
4	PAFZZ	5305-00-419-0820	80205	MS16996-10B	..SCREWS	2
5	PAOOO	1240-21-920-2782	36126	204721-001	CASE ASSEMBLY (For assembly breakdown see Figure 6).....	1
					END OF FIGURE	

UNIT AND DIRECT SUPPORT MAINTENANCE

**TELESCOPE, STRAIGHT: M145
(NSN 1240-01-411-6350)**

M145 SIGHT ASSEMBLY, PN 901581-001

REPAIR PARTS LIST

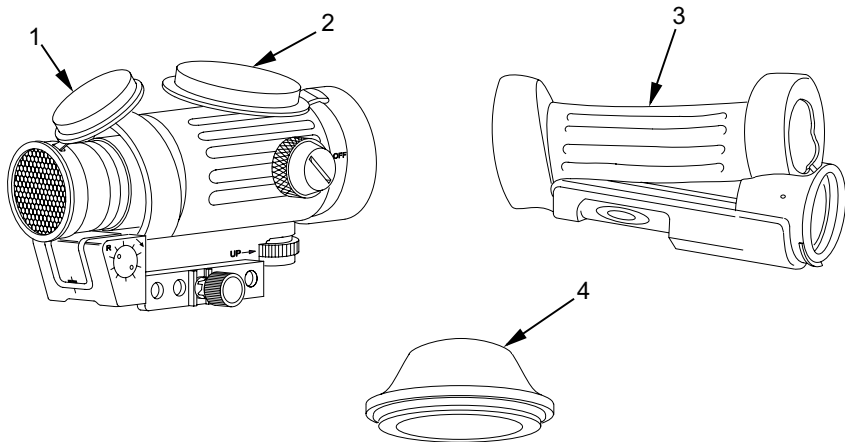

Figure 2. M145 Sight Assembly.

(1)	(2)	(3)	(4)	(5)	(6)	(7)
ITEM NO.	SMR CODE	NSN	CAGEC	PART NUMBER	DESCRIPTION AND USABLE ON CODE (UOC)	QTY
					GROUP 01 FIG. 2 ASSEMBLY, M145 SIGHT	
1	PCOZZ	6650-21-920-2502	36126	901798-001	CAP ASSEMBLY, FRONT	1
2	PCOZZ	6650-21-920-2495	36126	901799-001	CAP ASSEMBLY, REAR	1
3	PAFZZ	6650-21-920-2508	36126	204138-001	COVER, RUBBER	1
4	PAOOO	6160-21-920-2487	36126	901610-001	BATTERY COVER WITH O-RING (For assembly breakdown see Figure 3)	1
					END OF FIGURE	

UNIT MAINTENANCE

**TELESCOPE, STRAIGHT: M145
(NSN 1240-01-411-6350)**

BATTERY CAP ASSEMBLY

REPAIR PARTS LIST

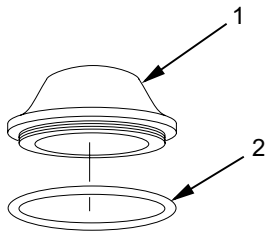

Figure 3. Battery Cap Assembly.

(1)	(2)	(3)	(4)	(5)	(6)	(7)
ITEM NO.	SMR CODE	NSN	CAGEC	PART NUMBER	DESCRIPTION AND USABLE ON CODE (UOC)	QTY
					GROUP 0101 FIG. 3 BATTERY CAP ASSEMBLY	
1	XAOZZ		36126	204250-001	BATTERY CAP	1
2	PAOZZ	5331-21-920-3021	36126	022-2347	O-RING	1

*See expendables for battery NSN

END OF FIGURE

UNIT MAINTENANCE

**TELESCOPE, STRAIGHT: M145
(NSN 1240-01-411-6350)**

LASER FILTER ASSEMBLY/SRD

REPAIR PARTS LIST

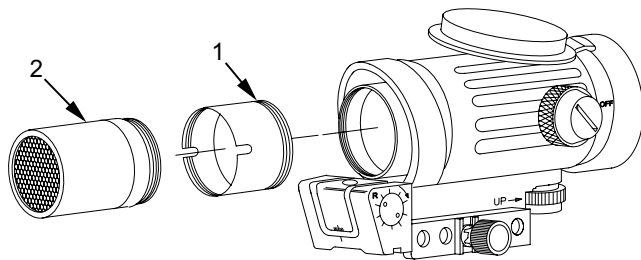

Figure 4. Laser Filter Assembly/SRD.

(1)	(2)	(3)	(4)	(5)	(6)	(7)
ITEM NO.	SMR CODE	NSN	CAGEC	PART NUMBER	DESCRIPTION AND USABLE ON CODE (UOC)	QTY
					GROUP 0102 FIG. 4 LASER FILTER ASSEMBLY/SRD	
1	PAOZZ	6650-21-920-2497	36126	901518-001	FILTER ASSEMBLY.....	1
2	PAOZZ	6650-21-920-2496	36126	901613-001	SIGNATURE- REDUCTION DEVICE.....	1
END OF FIGURE						

DIRECT SUPPORT MAINTENANCE

**TELESCOPE, STRAIGHT: M145
(NSN 1240-01-411-6350)**

MOUNT ASSEMBLY, PN 901615-001

REPAIR PARTS LIST

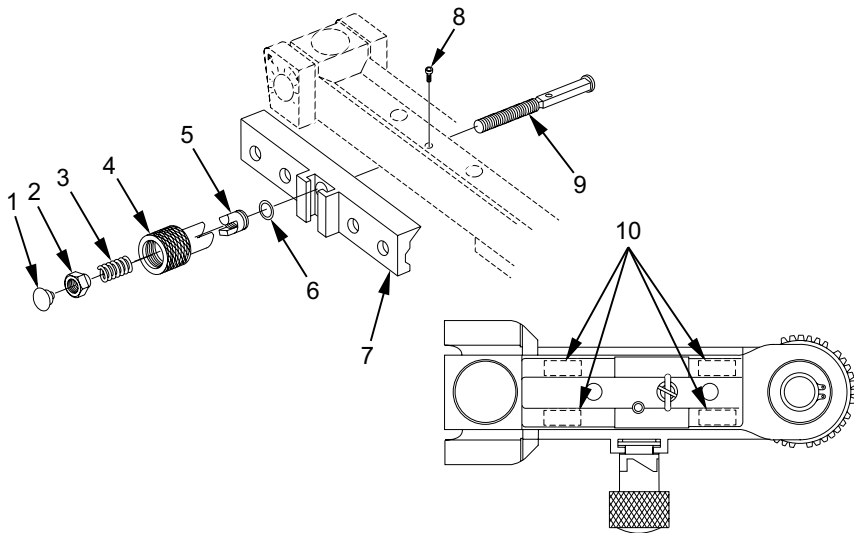

Figure 5. Mount Assembly.

(1)	(2)	(3)	(4)	(5)	(6)	(7)
ITEM NO.	SMR CODE	NSN	CAGEC	PART NUMBER	DESCRIPTION AND USABLE ON CODE (UOC)	QTY
					GROUP 02 FIG. 5 MOUNT ASSEMBLY	
1	PCFZZ	TBD	36126	204788-001	PLUG, PROTECTIVE, DUST.....	1
2	PAFZZ	5310-21-920-2488	36126	204782-001	NUT	1
3	PAFZZ	TBD	92830	C0360-055-0560M	SPRING.....	1
4	PAFZZ	5355-01-466-4063	19200	12598124	TORQUE KNOB.....	1
5	PAFZZ	5310-01-465-1402	19200	12598125	TORQUE NUT.....	1
6	PAFZZ	5310-01-466-4061	36126	12598127	FLAT WASHER.....	1
7	PAFZZ	1240-21-920-2514	36126	204723-001	LOCKING BAR.....	1
8	PAFZZ	5305-00-141-6179	80205	NAS1352C02-5	SCREW, SOCKET HEAD	1

(1)	(2)	(3)	(4)	(5)	(6)	(7)
ITEM NO.	SMR CODE	NSN	CAGEC	PART NUMBER	DESCRIPTION AND USABLE ON CODE (UOC)	QTY
					GROUP 02 FIG. 5 MOUNT ASSEMBLY	
9	PAFZZ	3040-01-466-4062	19200	12598123	SHAFT	1
10	PCFZZ	TBD	36126	204959-001	SHIM	4

END OF FIGURE

UNIT MAINTENANCE

**TELESCOPE, STRAIGHT: M145
(NSN 1240-01-411-6350)**

CASE ASSEMBLY, PN 204721-001

REPAIR PARTS LIST

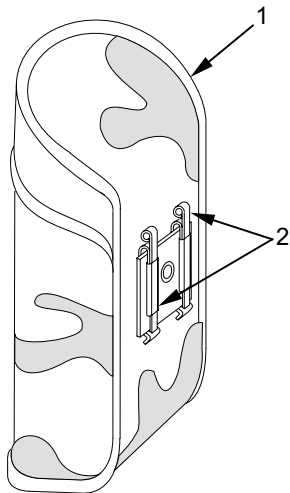

Figure 6. Case Assembly.

(1)	(2)	(3)	(4)	(5)	(6)	(7)
ITEM NO.	SMR CODE	NSN	CAGEC	PART NUMBER	DESCRIPTION AND USABLE ON CODE (UOC)	QTY

GROUP 03
FIG. 6 CASE ASSEMBLY

1	XAOZZ		36126	NPN	CASE	1
2	PAOZZ	5340-00-753-5580	81349	MILH9890TYPE10	KEEPER, BELT STRAP	2

END OF FIGURE

UNIT AND DIRECT SUPPORT MAINTENANCE**TELESCOPE, STRAIGHT: M145
(NSN 1240-01-411-6350)****NATIONAL STOCK NUMBER INDEX**

STOCK NUMBER	FIG.	ITEM
5305-00-141-6179	5	8
5340-00-753-5580	6	2
5310-01-465-1402	5	5
5310-01-466-4061	5	6
5355-01-466-4063	5	4
6160-21-920-2487	2	4
5310-21-920-2488	5	2
1240-21-920-2492	1	3
6650-21-920-2495	2	2
6650-21-920-2496	4	2
6650-21-920-2497	4	1
6650-21-920-2502	2	1
6650-21-920-2508	2	3
1240-21-920-2514	5	7
1240-21-920-2782	1	5
1240-21-920-2783	1	2

UNIT AND DIRECT SUPPORT MAINTENANCE

TELESCOPE, STRAIGHT: M145
(NSN 1240-01-411-6350)

PART NUMBER INDEX

PART NUMBER	FIG.	ITEM	PART NUMBER	FIG.	ITEM
C0360-055-056M	5	3	204788-001	5	1
MIL-H-9890TYPE 10	6	2	204959-001	5	10
MS16996-10B	1	4	901518-001	4	1
NAS1352C02-5	5	8	901581-001	1	1
022-2347	3	2	901610-001	2	4
12598124	5	4	901613-001	4	2
12598125	5	5	901614-001	1	2
12598127	5	6	901615-001	1	3
204138-001	2	3	901798-001	2	1
204250-001	3	1	901799-001	2	2
204663-001	5	9			
204721-001	1	5			
204723-001	5	7			
204782-001	5	2			

OPERATOR

**TELESCOPE, STRAIGHT: M145
(NSN 1240-01-411-6350)**

COMPONENTS OF END ITEM (COEI) AND BASIC ISSUE ITEMS (BII) LISTS

INTRODUCTION**Scope**

This work package lists COEI and BII for the telescope to help you inventory items for safe and efficient operation of the equipment.

General

The COEI and BII information is divided into the following lists:

INTRODUCTION - Continued

Components of End Item (COEI). There are no COEI for the telescope.

Basic Issue Items (BII). These essential items are required to place the telescope in operation, operate it, and to do emergency repairs. Although shipped separately packaged, BII must be with the telescope during operation and when it is transferred between property accounts. Listing these items is your authority to request/requisition them for replacement based on authorization of the end item by the TOE/MTOE. Illustrations are furnished to help you find and identify the items.

Explanation of Columns in the BII List

Column (1) — Illus Number. Gives you the number of the item illustrated.

Column (2) — National Stock Number (NSN). Identifies the stock number of the item to be used for requisitioning purposes.

Column (3) — Description, CAGEC, and Part Number. Identifies the Federal item name (in all capital letters) followed by a minimum description when needed. The stowage location of COEI and BII is also included in this column. The last line below the description is the CAGEC (Commercial and Government Entity Code) (in parentheses) and the part number.

Column (4) — Usable On Code. When applicable, gives you a code if the item you need is not the same for different models of equipment.

Column (5) — Unit of Measure (U/M). Indicates the physical measurement or count of the item as issued per the National Stock Number shown in column (2).

Column (6) — Qty Rqr. Indicates the quantity required.

BASIC ISSUE ITEMS (BII) LIST

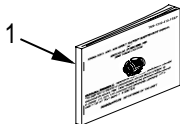

Table 1. Basic Issue Items List.

(1) ILLUS NUMBER	(2) NATIONAL STOCK NUMBER	(3) DESCRIPTION, CAGEC, AND PART NUMBER	(4) USABLE ON CODE	(5) U/M	(6) QTY RQR
1		MANUAL, TECHNICAL, OPERATOR'S, UNIT, AND DIRECT SUPPORT MAINTENANCE		EA	1

END OF WORK PACKAGE

UNIT AND DIRECT SUPPORT MAINTENANCE**TELESCOPE, STRAIGHT: M145
(NSN 1240-01-411-6350)****EXPENDABLE AND DURABLE ITEMS LIST**

INTRODUCTION**Scope**

This work package lists expendable and durable items that you will need to operate and maintain the telescope. This list is for information only and is not authority to requisition the listed items. These items are authorized to you by CTA 50-970, Expendable/Durable Items (Except Medical, Class V, Repair Parts, and Heraldic Items), or CTA 8-100, Army Medical Department Expendable/Durable Items.

Explanation of Columns in the Expendable/Durable Items List

Column (1) – Item Number. This number is assigned to the entry in the list and is referenced in the narrative instructions to identify the item (e.g., Use optical lens cleaning compound (item 2, WP 0036 00)).

Column (2) – Level. This column identifies the lowest level of maintenance that requires the listed item (C = Operator/Crew, O = Unit, F = Direct Support).

Column (3) – National Stock Number (NSN). This is the NSN assigned to the item which you can use to requisition it.

Column (4) – Item Name, Description, Commercial and Government Entity Code (CAGEC), and Part Number (P/N). This column provides the other information you need to identify the item.

Column (5) – Unit of Measure (U/M). This code shows the physical measurement or count of an item, such as gallon, dozen, gross, etc.

EXPENDABLE AND DURABLE ITEMS LIST**Table 1. Expendable and Durable Items List.**

(1) ITEM NUMBER	(2) LEVEL	(3) NATIONAL STOCK NUMBER	(4) ITEM NAME, DESCRIPTION, CAGEC, PART NUMBER	(5) U/M
1	O	6135-01-398- 5922	Battery (OE890) DL1/3N	EA
2	O	6850-00-392- 9751	Cleaning Compound, Optical Lens (06650) Lens Cleaner	OZ
3	O	6850-00-754- 2671	Compound, Anti-fogging	OZ

EXPENDABLE AND DURABLE ITEMS LIST - Continued**Table 1. Expendable and Durable Items List - Continued.**

(1) ITEM NUMBER	(2) LEVEL	(3) NATIONAL STOCK NUMBER	(4) ITEM NAME, DESCRIPTION, CAGEC, PART NUMBER	(5) U/M
4	O	8030-01-303- 0502	Locktite 680 (05972) 68035	BT
5	O	6640-00-663- 0832	Paper, Lens, Type 1 (81348) NNN-P-40	BK

Table 1. Expendable and Durable Items List – Continued.

(1) ITEM NUMBER	(2) LEVEL	(3) NATIONAL STOCK NUMBER	(4) ITEM NAME, DESCRIPTION, CAGEC, PART NUMBER	(5) U/M
6	O	8030-00-181- 8372	Primer, Sealing Compound (05972) 74756	CN

END OF WORK PACKAGE

INDEX

Subject WP Sequence No. - Page No.

A

Assembly and Preparation for Use 0005 00-1

B

Basic Issue Items (BII) 0035 00-1

Battery Cap O-ring Maintenance 0016 00-1

Battery Maintenance 0015 00-1

C

Cleaning 0010 00-1

Components of End Item 0035 00-1

Controls and Indicators, Operator 0004 00-1

Corrosion Prevention and Control (CPC) 0001 00-3

INDEX

Subject WP Sequence No. - Page No.

D

Description and Use of Operator	
Controls and Indicators	0004 00-1
Destruction of Army Materiel to Prevent	
Enemy Use	0001 00-5

E

Equipment Characteristics, Capabilities, and Features	0002 00-1
Equipment Data	0002 00-7
Expendable and Durable Items List	0036 00-1

INDEX - Continued

<u>Subject</u>	<u>WP Sequence No. - Page No.</u>
G	
General Information - Scope	0001 00-1
H	
How To Use This Manual	viii
I	
Illustrated List of Manufactured Items	0022 00-1
L	
Lens Cleaning Procedures	0010 00-1

INDEX - Continued

<u>Subject</u>	<u>WP Sequence No. - Page No.</u>
L	
Lens Cover Maintenance	0017 00-1
List of Effective Pages	A
Location and Description of Major Components	0002 00-5
M	
Maintenance Allocation Chart	
Introduction	0024 00-1
Table	0025 00-1
Maintenance Forms, Records, and Reports	0001 00-2
Mount Assembly Maintenance	0019 00-1

INDEX - Continued

Subject WP Sequence No. - Page No.

N

National Stock Number (NSN) Index	0033 00-1
Nomenclature Cross Reference List	0001 00-6
Nuclear, Biological, and Chemical (NBC)	
Contamination	0007 00-4

O

Operating Procedures	0006 00-1
Operation Under Usual Conditions	0006 00-1
Operation Under Unusual Conditions	0007 00-1
Operator Controls and Indicators	0004 00-1
Ozone Depleting Substances	0001 00-5

INDEX - Continued

Subject WP Sequence No. - Page No.

P

Part Number Index	0034 00-1
Preparation for Storage or Shipment	0001 00-5, 0011 00-1
Preventive Maintenance Checks and Services (PMCS)	
Introduction, Unit	0013 00-1
PMCS Procedures, Unit	0014 00-1

R

References	0023 00-1
Repair Parts and Special Tools List	
Introduction	0026 00-1
Parts Lists	0027 00 thru 0032 00

INDEX - Continued

Subject WP Sequence No. - Page No.

R

Reporting Equipment Improvement	
Recommendations (EIR)	0001 00-3
Reporting Errors and Recommending	
Improvements	ii
Rubber Cover Maintenance	0020 00-1

S

Service Upon Receipt	0012 00-1
Signature Reduction Device (SRD) and	
Laser Filter Maintenance	0018 00-1
Supporting Information for Repair Parts, Special	
Tools, TMDE, and Support Equipment	0001 00-6

INDEX - Continued

Subject WP Sequence No. - Page No.

T

Theory of Operation	0003 00-1
Torque Limiting Knob/Shaft Maintenance	0021 00-1
Troubleshooting	
Direct Support	0009 00-1
Unit	0008 00-1

U

Unusual Environments and Weather	0007 00-2
--	-----------

W

Warning Summary	a
Warranty	0001 00-5

By Order of the Secretary of the Army:

ERIC K. SHINSEKI
General, United States Army
Chief of Staff

Official:



JOEL B. HUDSON
Administrative Assistant to the
Secretary of the Army

9935401

DISTRIBUTION:

To be distributed in accordance with initial distribution number (IDN) 410462 requirements for TM 9-1240-415-13&P.

PIN: 077547-000